

# ***Technical Service Manual***

***(All Models)***

# Index

	Page
<b>Cabinet Installation and Set-Up</b>	<b>4</b>
Electrical Requirements	5
Conductors and Circuits	6
Cabinet Installation and Set-Up Checklist	7
Cabinet Installation and Set-Up (Swing & Slide Doors)	8
GDM/T - Series Freezers	9
Remote Condensing Unit	10
Temperature Control Altitude Adjustment	11
Temperature Control Altitude Adjustment(new temp. control)	12
Defrost Controls	13-14
<b>Preventative Maintenance</b>	<b>16</b>
Cabinet Maintenance Schedule	17
Condenser Cleaning	18
<b>Refrigeration Section</b>	<b>20</b>
Polyol Ester Lubricant - The CFC Report	21
Service Contractors: <i>Attention Please</i>	22
Basic Refrigeration - The Capillary Tube System	23
The Refrigeration Cycle	24
True's Remote System - How it Works	25
Basic Refrigeration - Control of Liquid Refrigerant Floodback...	26
<b>General Maintenance &amp; Repairs</b>	<b>28</b>
Top Removal for TBB and TDD Units	29
Top Removal for TD and T-GC Units	30
TPPCountertop Replacement Instructions	31
Top Removal for Various Coolers - TSSU, TWT, TUC	32
Top Removal for TRCB 50 and 79	33
End Cap Replacement-T-Series Swing Door	34-35
Side Panel Replacement - GDM Series	36
Side Panel Replacement - GDM-33C-PT	37
Floral Case Baffle Installation	38
GDM-23FC Mirror Retrofit Kit	39
Undercounter Refrigerator/Freezer Perimeter Heater Wire Replacement	40
GDM & T-Series Freezer Perimeter Heater Wire Replacement	41
TD-Series and Glass Chillers	42
Temperature Control Replacement for Cabinets Larger than 1/3 HPCompressors	43-47
Temperature Control Change-Out - GDM	48
Temperature Control Change-Out - GDM & T-Series	49
Replacing Temperature Controls in GDM-7, GDM-10, & GDM-12 models	50
Surge Protector's for the GDM-Series	51-52
<b>Door and Lock Repair</b>	<b>54</b>
Glass Insert - Slide Door	55
Slide Door Instruction - To improve slide door closing	56
Wiper Gasket Installation	57
Removal and Installation of GDM-Swing Door	58-59
Torsion Spring Replacement - Swing Door	60-61
IDLamp Replacement	62

# Index

	<b>Page</b>
Glass Insert - Swing Door _____	63-64
Glass Insert Gas Release (High Altitude Installation) _____	65
GDM & T-Series IDLGlass Insert Replacement _____	66
Replacement of Door Frame Heater on IDL Freezer Doors _____	67
IDL Door Wire Harness Replacement _____	68-69
Shimming the Glass Insert _____	70-71
Lock Installations - GDM Single Swing Door (GDM-23/26) _____	72
Barrel Lock Installation (GDM Slide DoorModels) _____	73
Slide Barrel Lock (Top View) _____	74
Slide Barrel Lock (Front View) _____	75
Lock Installation (GDM-5 & GDM-5PT Swing Door Models) _____	76
Ratchet Lock & Plastic Door Stop - Slide Door _____	77-78
Lock Installation - TD Models _____	79
<b>General Instructions _____</b>	<b>80</b>
Overshelf Option - TSSU, TWT, TUC _____	81
Installing The Crumb Catcher _____	82
Field Installing The TSSU Series 19” Cutting Board _____	83
Anchoring the TSSU Hood Cover _____	84
Installing the TTPSeries Service Shelf _____	85
Field Installing the TPPService Shelf _____	86
SneezeGuard Option - TSSU _____	87
Castor and Leg Frame Installation _____	88
GDM-33C-PT Castor Mounting Assembly _____	89
TDD-1 CO <sub>2</sub> Knock-out _____	90
TDD-2,3,4 (and Club Top models) CO <sub>2</sub> Knock-out _____	91
Vandal Panel Installation for a GDM-33CPT-54 _____	92
Vandal Panel - GDM-69 _____	93-94
<b>Troubleshooting _____</b>	<b>96</b>
Calibrate Temperature Control _____	97-98
Troubleshooting and Service Chart _____	99-100
Capillary Tube Replacement Instructions - Upright GDM/T-Series Equipment _____	101-102
Refrigeration Trouble Shooting Chart - Refrigerator _____	103-104
Refrigeration Trouble Shooting Chart - Freezer _____	105-106
Capillary Tube Replacement Instructions - Refrigerators and Freezers _____	107
Field Troubleshooting _____	108-110
<b>Troubleshooting Fluorescent Lighting Circuits</b>	
Rapid Start, Electric, and Preheat Fluorescent Light Circuits _____	111
GDM & T Series Coolers IDLConnector _____	112
<b>Equipment Care and Cleaning _____</b>	<b>114</b>
Cleaning Your Cabinet _____	115
Stainless Steel Equipment Care and Cleaning (NAFEM) _____	116-120



***CABINET  
INSTALLATION  
AND SET-UP***

Please read these instructions. Failure to follow maintenance guidelines may result in a **non-warranted** service call.



## ***ELECTRICAL REQUIREMENTS***

There are several factors that will affect the proper operation of your True unit. Among these factors, the electrical installation is the most important and should always be checked before connecting your True cabinet as follows:

1. Make sure the circuit is dedicated exclusively to your True unit.
2. Make sure the electrical installation complies with national, state, and local codes.
3. Make sure the circuit is properly ground.
4. Check circuit for proper voltage at receptacle  
(+/-10% 115 Volt)  
(- 5% + 10% 208/230 Volt)
5. Make sure that the wire gauge and breaker sizes are correct and comply with the minimum allowance for voltage drops

***WARNING: FAILURE TO COMPLY WITH THESE REQUIREMENTS MIGHT RESULT IN PERSONAL INJURY AND (OR) PROPERTY DAMAGE, AND WILL VOID WARRANTY.***

# CONDUCTORS AND CIRCUITS

## Wire Gauge for 2% Voltage Drop in Supply Circuits

115 Volt Amps	<i>Distance In Feet To Center of Load</i>											
	20	30	40	50	60	70	80	90	100	120	140	160
2	14	14	14	14	14	14	14	14	14	14	14	14
3	14	14	14	14	14	14	14	14	14	14	14	14
4	14	14	14	14	14	14	14	14	14	12	12	12
5	14	14	14	14	14	14	14	12	12	12	10	10
6	14	14	14	14	14	14	12	12	12	10	10	10
7	14	14	14	14	14	12	12	12	10	10	10	8
8	14	14	14	14	12	12	12	10	10	10	8	8
9	14	14	14	12	12	12	12	10	10	8	8	8
10	14	14	14	12	12	10	10	10	10	8	8	8
12	14	14	12	12	10	10	10	8	8	8	8	6
14	14	14	12	10	10	10	8	8	8	6	6	6
16	14	12	12	10	10	8	8	8	8	6	6	6
18	14	12	10	10	10	8	8	8	8	8	8	5
20	14	12	10	10	8	8	8	6	6	6	5	5
25	12	10	10	8	8	6	6	6	6	5	4	4
30	12	10	8	8	6	6	6	6	5	4	4	3
35	10	10	8	6	6	6	5	5	4	4	3	2
40	10	8	8	6	6	5	5	4	4	3	2	2
45	10	8	6	6	6	5	4	4	3	3	2	1
50	10	8	6	6	5	4	4	3	3	2	1	1

230 Volts Amps	<i>Distance In Feet To Center of Load</i>											
	20	30	40	50	60	70	80	90	100	120	140	160
5	14	14	14	14	14	14	14	14	14	14	14	14
6	14	14	14	14	14	14	14	14	14	14	14	12
7	14	14	14	14	14	14	14	14	14	14	12	12
8	14	14	14	14	14	14	14	14	14	12	12	12
9	14	14	14	14	14	14	14	14	12	12	12	10
10	14	14	14	14	14	14	14	12	12	12	10	10
12	14	14	14	14	14	14	12	12	12	10	10	10
14	14	14	14	14	14	12	12	12	10	10	10	8
16	14	14	14	14	12	12	12	10	10	10	8	8
18	14	14	14	12	12	12	10	10	10	8	8	8
20	14	14	14	12	12	10	10	10	10	8	8	8
25	14	14	12	12	10	10	10	10	8	8	6	6
30	14	12	12	10	10	10	8	8	8	6	6	6
35	14	12	12	10	10	10	8	8	8	6	6	6
40	14	12	10	10	8	8	8	6	6	6	5	5
50	12	10	10	8	8	6	6	6	6	5	4	4
60	12	10	8	8	6	6	6	6	5	4	4	3
70	10	10	8	6	6	6	5	5	4	4	3	2
80	10	8	8	6	6	5	5	4	4	3	2	2
90	10	8	6	6	6	5	4	4	3	3	2	1
100	10	8	6	6	5	4	4	3	3	2	1	1

## **CABINET INSTALLATION AND SET UP CHECKLIST**

- 1) Make sure cabinet is plugged into dedicated outlet. Before plugging in cabinet check to make sure voltage is adequate for your cabinet. **Do not use an extension cord, this will void cabinet warranty.**
- 2) Follow installation instructions for your specific cabinet. Each cabinet is shipped with specific installation and set up instructions. It is very important to read all information sent with your new cabinet
- 3) Make sure shipping blocks (slide doors) and door support brackets (swing doors) are removed. Doors will not function correctly if this step is not followed.
- 4) Make sure that your cabinet is leveled correctly. Follow specific instructions with your cabinet and use castor shims were they are needed. Make sure that legs and castors are installed per instructions. If directions are not followed this may cause premature unwarranted failure of cabinet legs or castors. If your cabinet is not level this can cause performance problems that will not be covered as warranty repairs.
- 5) When cabinet is set in its final location, make sure the specific clearance guidelines are followed. These are very important for ventilation in the condensing unit area. **If not followed can cause premature compressor failure.**
- 6) Follow altitude adjustment for temperature control if applicable.
- 7) **IF YOU HAVE ANY QUESTIONS ABOUT SET UP OR INSTALLATION OF YOUR NEW CABINET PLEASE CALL OUR TECHNICAL SERVICE DEPARTMENT AT 1-800-325-6152.**

## INSTALLATION INSTRUCTION

### CABINET INSTALLATION AND SET-UP (SWING & SLIDE DOORS)

#### SWING DOORS

A. Remove all other tape securing the doors to the cooler. Remove the blue foam blocks approximately 1"x3"x1" (2.5 x 7.6 x 2.5 cm) that are between the door and the cooler. One foam block is located on each side of the door frame. (left and right).

#### NOTE

Your True Merchandiser has been secured for safe shipping. During installation, it is necessary to remove the door support bracket.

- B. Remove the two phillips screws that secure the bracket to the door. (see figure 1).
- C. Remove bracket and save for future shipping.
- D. Replace screws securely into door.

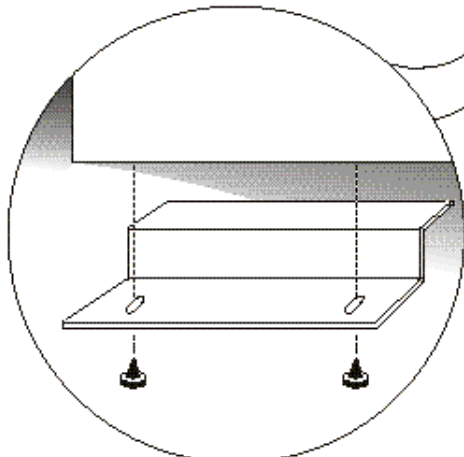

(figure 1)

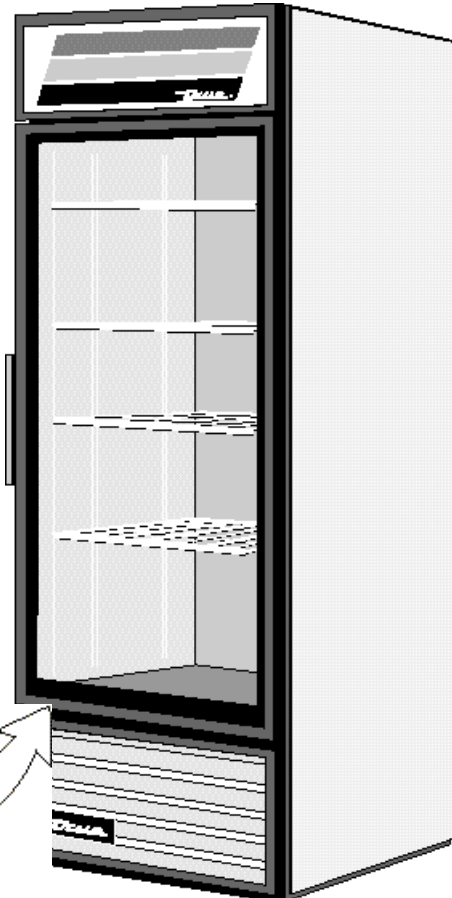

#### SLIDE DOORS

A. Remove all transparent tape on the door area. Remove the foam blocks in top channel in front on the right door approximately 1"x1"x20" (2.5 x 2.5 x 50 cm).

B. Remove both plastic brackets secured by tape from under the left door.

C. Open the left door.

D. Remove the foam block from the top channel behind the left door.

E. Remove both plastic brackets from under the right door (see figure 2).

#### NOTE

Door packing materials should NOT be removed until cooler is placed on location.

**TRANSPORTATION OF THE COOLER WITHOUT THE DOOR PACKING MATERIALS IN PLACE CAN RESULT IN DAMAGE TO DOORS, DOOR ROLLERS AND V-TRACK**

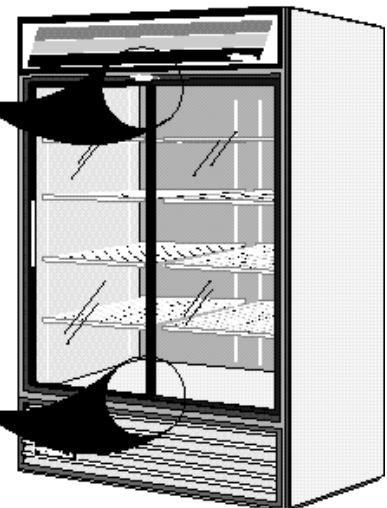
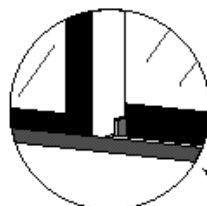
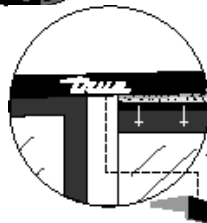



# INSTALLATION INSTRUCTION

## GDM / T-Series Freezers

### Installing Castors

Install castors in the bottom rail assembly on the underside of the cooler. Castors with brakes should be installed in front. To obtain maximum strength and stability of the unit, it is important that you make sure each castor is secured with a 3/4" (19mm) open-end wrench. The bearing race on the castor must make firm contact with the rail.

### Installing Leg Levelers

Screw leg levelers into the four corners of the lower rail assembly (larger models include levelers centered front and back also).

### CAUTION

To avoid damage to lower rail assembly, raise unit slowly and carefully to upright position.

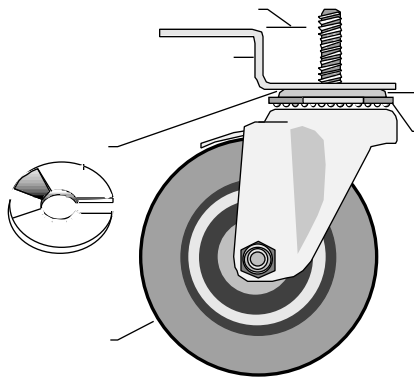

figure 3.

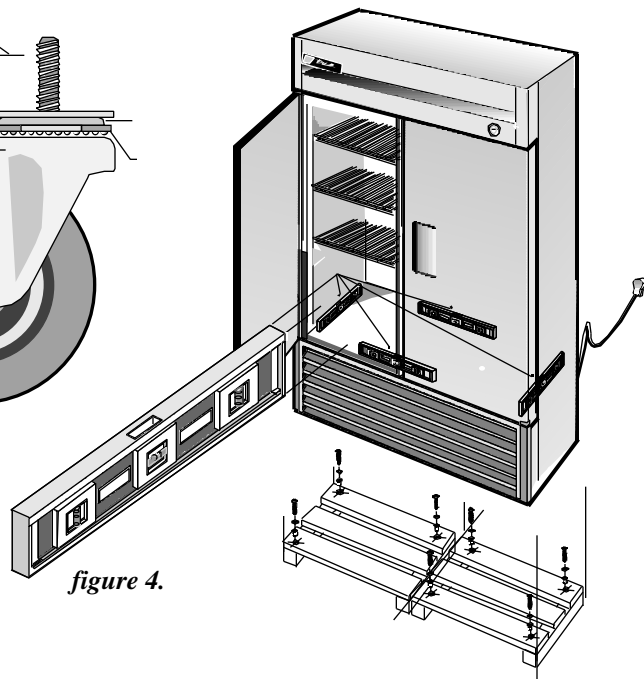

figure 4.

### LEVELING

**A.** Set unit in its final location. Be sure there is adequate ventilation in your room. Under extreme heat conditions, (100°F+, 38°C+), you may want to install an exhaust fan.

**Warning**  
**Warranty is void if ventilation is insufficient.**

**B.** Proper leveling of your True cooler is critical to operating success. Effective condensate removal and door operation will be effected by leveling.

**C.** The cooler should be leveled front to back and side to side with a level (see figure 4). Place the level in the interior floor of the unit in the four positions illustrated.

For Castored Models:

Four shims have been provided in warranty packet for leveling castored units posi-

tioned on uneven floors. Shims must be positioned between rail end and bearing race. (see figure 3).

If the cabinet is not level use a 3/4" (19mm) open-end wrench to turn the anchoring bolt under the bearing race counter-clockwise until the cabinet is level.

Install the desired number of shims, making sure the slot of the shim is in contact with the threaded stem of the castor.

If more than one shim is used, turn the slot at a 90° angle so they are not in line.

Turn the anchoring bolt clockwise with a 3/4" (19mm) open-end wrench to tighten and secure the castor.

Leg Levelers For GDM Models:

If the cabinet is not level adjust leg levelers by first relieving weight to leveler and adjusting by either hand or wrench. Repeat with all leg levelers until cabinet is level in all directions.

**D.** Ensure that the drain hose or hoses are positioned in the pan.

### IMPORTANT

**Make certain the metal strap holding the compressor during shipment is removed. Failure to cut strap could result in excessive noise and vibration (freezer).**

**E.** Free plug and cord from inside the lower rear of the cooler(do not plug in).

**F.** The unit should be placed close enough to the electrical supply so that extension cords are never used.

### Warning

**Compressor warranties are void if the unit is more than 6-1/2 ft. (2m) from plug-in connection.**

## INSTALLATION INSTRUCTION

### Remote Condensing Unit

For cabinet installation, use installation instructions with cabinet.

**Receiving:** Upon receiving this piece of equipment remove all outer packaging and inspect for concealed damage. If damage is found, indicate such on the carriers Bill of Lading for claim to be filed. In order to minimize damage to this equipment, it is recommended that the packaging remains in place until it is in its final location.

Condensing units located indoors or in confined areas must have adequate ventilation. Condensing units require 1000 cfm of air per ton of refrigeration.

True Manufacturing Company strongly recommends the use of compressor crankcase heaters and headmaster valves be used at all times with a remote compressor unit. Not using these components may void the compressor warranty.

**Refrigerant Lines:** All refrigerant piping should be ACR type. It is recommended that all brazed joints be made with "hard solder" such as Silphos or Unibraze. Solder such as 95-5 or other soft solders are not recommended.

All suction lines must be insulated, with at least 1/2" wall insulation. Keep all lines as short as possible.

Always pitch suction lines downward in the direction of flow. Generally 1/2" pitch for each 10 ft. of line is adequate for good oil return. Field installation vibration eliminators should be field installed

parallel with the compressor crank shaft and as close to the compressor as possible.

**Leak Check and Evacuation:** After all refrigerant line connections have been complete, the entire system should be leak checked. This includes field and factory connections. Charge system with refrigerant vapor and add enough nitrogen to raise pressure to 150 PSIG maximum.

Leak check the entire system. Make repairs as necessary.

**Evacuation Process:** To obtain the proper level of dehydration in the refrigeration system, a vacuum of at least 500 microns must be drawn. Do not use the system's compressor as a vacuum pump and do not operate compressor while system is in a vacuum.

Open all system service valves to discharge any pressure in the system. Connect vacuum pump to high and low side of system. Pull vacuum.

Break the vacuum with system refrigerant. Pull vacuum again, down to 500 microns or lower.

Shut valves before charging.

**Charging Process:** When initially charging a system that is in a vacuum, liquid refrigerant can be added directly into the receiver tank **without compressor running**.

If you have difficulty charging the correct amount of refrigerant into the system you may start the system to complete the charging process.

Add the correct amount or until the sight glass indicates a full charge, with a clear window, bubbles indicate more refrigerant is required. Care should be taken not to overcharge the system at this point. The evaporator fans must be operational while charging; cooler fans must run continuously, freezer fans will be delayed by the fan control. Make sure freezer fans are running during final charging process.

Keep a close check on suction and discharge pressures. After system has stabilized, check for excessive liquid floodback to the compressor. If flooding occurs (less than 8° superheat in freezers, 12° in coolers) adjust expansion valve Clockwise, 1/2 a turn at a time, recheck before leaving installation.

Check full load amps on the compressor, this can be found on the compressors nameplate, Check compressor oil level. Normal charge is indicated by 1/2 of the sight glass having oil in it.

**Final Check:** Check high and low pressure control settings. Set thermostat to desired cabinet temperature. Check defrost timer settings (if applicable). Check voltage, this must be 100% of the nameplate rated voltage for operation. Anything more or less should be corrected immediately.

Replace all service valve caps and secure all unit covers.

# INSTALLATION INSTRUCTION

## TEMPERATURE CONTROL ALTITUDE ADJUSTMENT

Figure 1

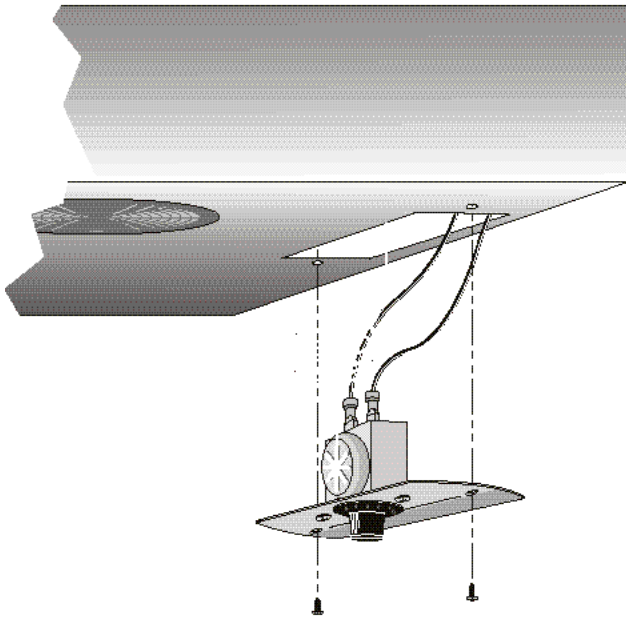

This scale may be used as a guide for measuring degrees of rotation required for altitude correction. The arrows indicate direction of screw rotation.

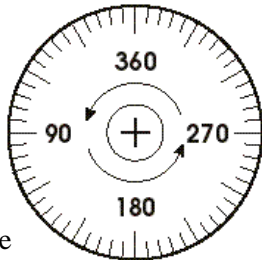

### REQUIRED TOOLS

- Phillips Head Screwdriver
- Hex Head Driver
- Jewelers Screwdriver

### IMPORTANT

*Upright models ordered with "High Altitude" temperature controls are pre-calibrated and do not require adjustment.*

Chart	
Height	CCW Adjustment (based on 360°/complete turn)
2000'	42°
3000'	78°
4000'	114°
5000'	150°
6000'	186°
7000'	222°
8000'	258°
9000'	294°
10,000'	330°

Figure 2

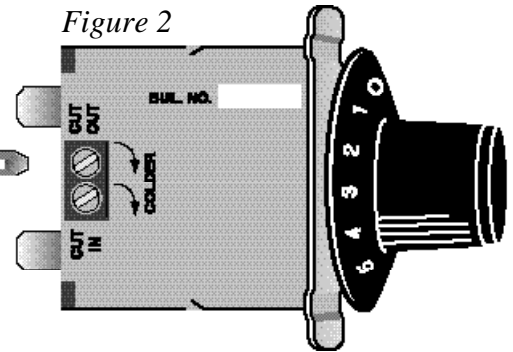

\_\_\_\_\_ **STEP 1** \_\_\_\_\_

Unplug the cooler.

\_\_\_\_\_ **STEP 2** \_\_\_\_\_

Turn the temperature control to the "9" position.

\_\_\_\_\_ **STEP 3** \_\_\_\_\_

Remove the screws that secure the mounting plate to the evaporator top. ("A") See figure 1.

\_\_\_\_\_ **STEP 4** \_\_\_\_\_

Pull control down gently from housing.

\_\_\_\_\_ **STEP 5** \_\_\_\_\_

Turn screws counterclockwise (CCW) See Chart and figure 2.

\_\_\_\_\_ **STEP 6** \_\_\_\_\_

Reassemble to cooler housing and return the temperature control to the "5" position.

## INSTALLATION INSTRUCTION

### Danfoss Temperature Control Adjustment for High Altitude Applications

#### Terms:

Cut-out - Temperature sensed by the controller that shuts the compressor off.

Cut-in - Temperature sensed by the controller that turns the compressor on.

#### Instructions:

##### STEP 1

Mechanical temperature controllers are affected when functioning at high altitude. The cut-in and cut-out temperatures will be colder than when the controller function closer to sea level.

##### STEP 2

For installations above 2,000 ft., it may be necessary to “warm-up” the set points. To make the adjustment, insert the appropriate tool in each adjustment screw and turn 1/4 of a revolution clock-wise (to the right). This procedure will adjust both the cut-in and cut-out about 2°F warmer.

##### STEP 3

Make sure to re-connect the pink wires to the proper spade terminal when re-installing.

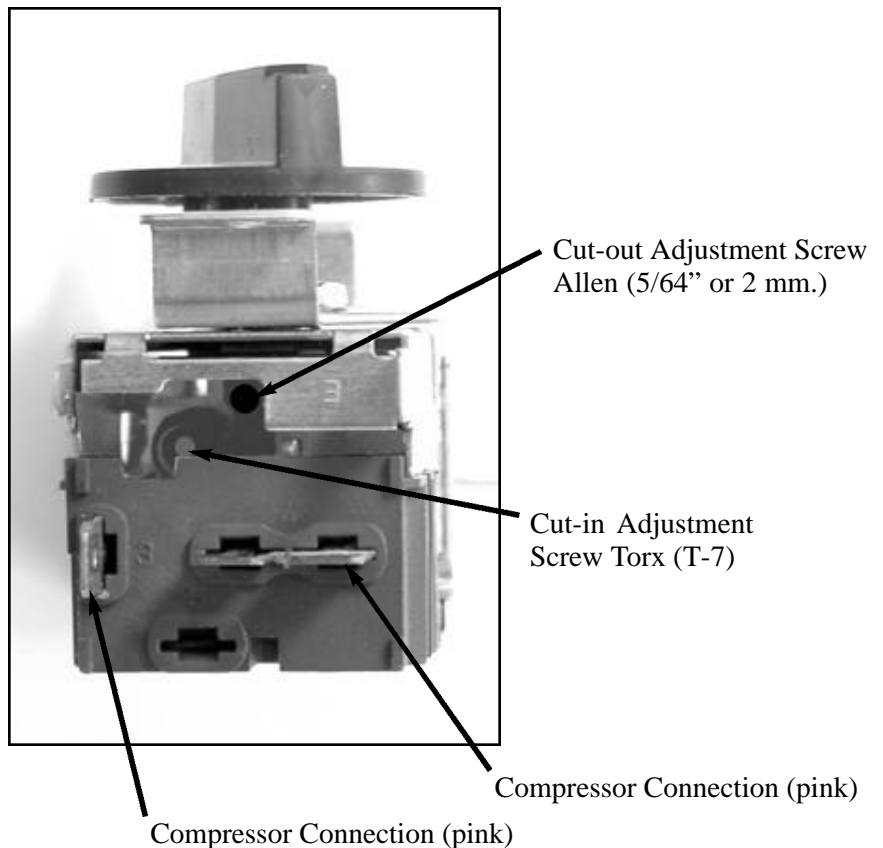

## DEFROST CONTROLS

### Defrost Time Clock Adjustment

#### Recommended Defrost Settings

True Manufacturing has factory set your defrost time clock to a recommended time and duration defrost scenario. All refrigeration equipment operating below 30°F will accumulate frost on the evaporator coil and will require routine defrost. Your True equipment has been designed for three defrost periods (8:00 a.m., 12:00 p.m. and 4:00 p.m.).

If you decide to deviate from these defrost time settings please follow the procedures and adjustment below.

#### REQUIRED TOOLS

- Slotted Screwdriver

#### Locating The Defrost Timer

Take off lower grill assembly by removing four (4) corner screws.

Single door models:

Defrost timer is located in the lower right corner behind the louvered grill.

Two door models:

Defrost timer is located in the middle of the cabinet, behind the louvered grill. Timer is mounted to the left of the centered ballast box.

Three door models:

Defrost timer is located on the left upright post behind the louvered grill.

#### Adjusting The Defrost Control

(time initiated, temperature terminated)

Your True freezer contains a defrost system that is temperature terminated, however the time clock has been designed with a time termination back-up so that the defrost period will not exceed twenty minutes. While True recommends 3 defrost periods not to exceed 20 minutes the procedure below should be followed to customize your specific needs.

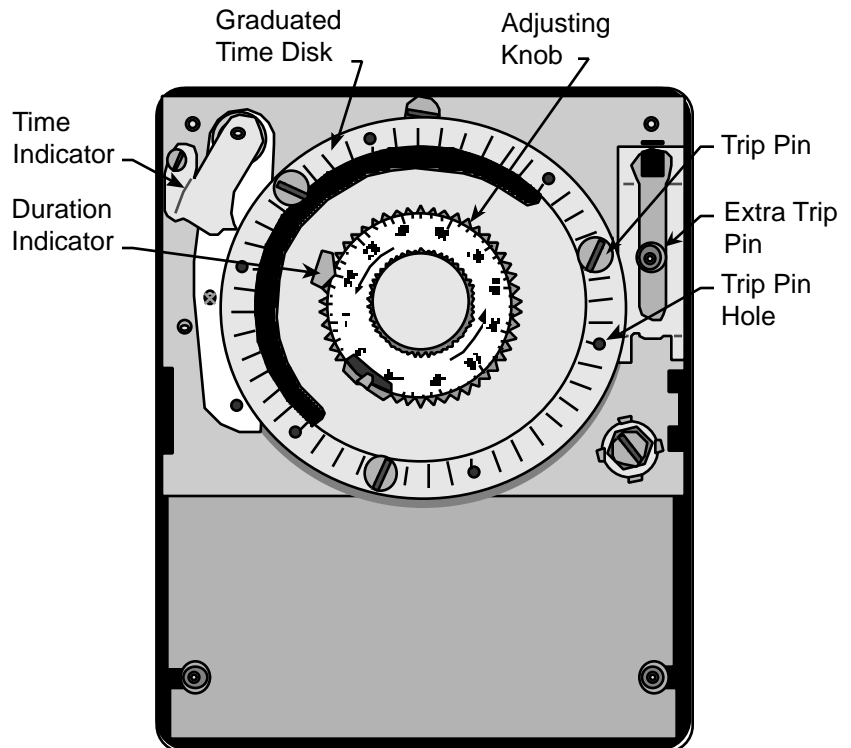

#### Warning

Always follow the manufactures recommended settings when programming the amount and duration of the defrost cycles.

#### STEP 1

Referencing the outer graduated time disk, position the current time of day to align with the "TIME" indicator. To move the graduated time disk, grasp the adjusted knob and turn counter clockwise until the current time of day aligns with the "TIME" indicator.

#### STEP 2

In order to program the time to begin the defrost cycle, insert threaded trip pins into the graduated time disk hole that corresponds to your customized defrost needs.

#### STEP 3

True recommends a 20 minute defrost cycle three times per day. Changing the recommended duration requires pressing down and sliding the copper duration

## DEFROST CONTROLS

### 2. TIME INITIATED, TIME TERMINATED

Like in the time initiated, temperature terminated controls; these systems have a temperature sensor that will disconnect the heaters to keep the cabinet from over heating. However it won't restart the freezing cycle until the control completes the factory set time, which in our case is usually 20 minutes. These systems are also equipped with temperature sensors to delay the fan motors once the defrost cycle has been completed, to prevent the circulation of warm air inside the cabinet.

To adjust the defrost cycle time there is only one possible adjustment; Once the cabinet has reach the design temperature, pick the time of the day that you want the unit to defrost. Turn the actuating gear clockwise until the contacts change position initiating the defrost cycle.

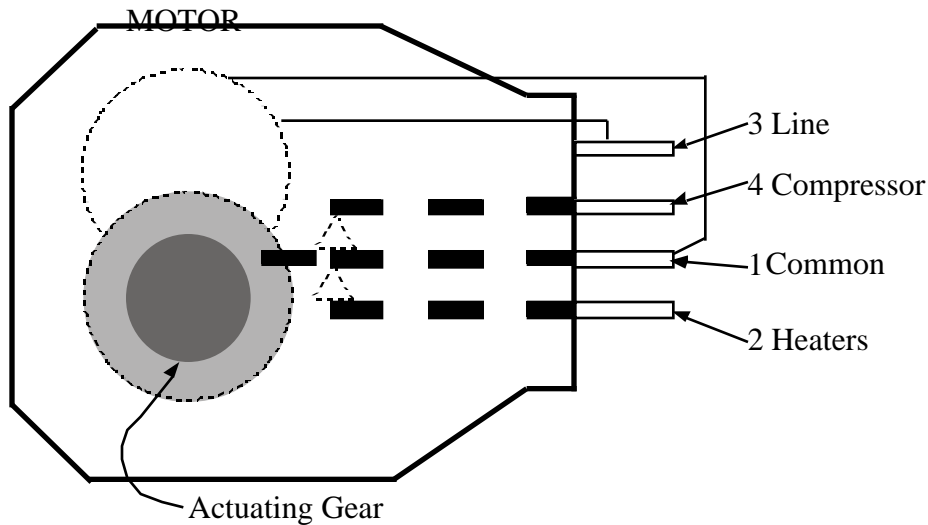

# **Notes**



***PREVENTATIVE  
MAINTENANCE***

Please read these instructions. Failure to follow maintenance guidelines may cause a **non-warranted** cabinet repair service.





## **CABINET MAINTENANCE SCHEDULE**

---

***Monthly, Quarterly, and Yearly***

### **CABINET MAINTENANCE SCHEDULE**

#### **MONTHLY**

1. Check product temperature.
2. Brush off condenser coil.
3. Inspect lamps and lamp holder connections.

#### **QUARTERLY**

1. Check physical condition of condenser coil and evaporator coil (straighten fins if necessary).
2. Blow out condenser coil with compressed air.
3. Brush off evaporator coil if needed.
4. Check physical condition of gaskets and also make sure they are sealing correctly.

#### **YEARLY**

1. Check operation of all moving parts (fan motors, doors, defrost timers, & IDL door cords)
2. Check all electrical connections, make sure they are all tight and crimps in good condition.
3. Check defrost timer contacts, make sure they are not pitted.
4. Check rear condenser coil screen (clean if necessary).

## GENERAL MAINTENANCE

### CONDENSER CLEANING

Step 4

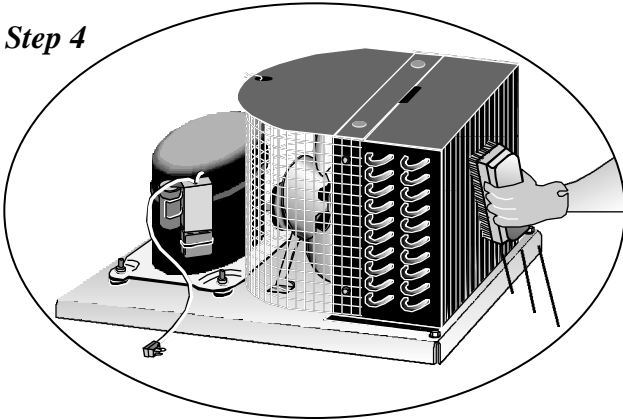

Step 6

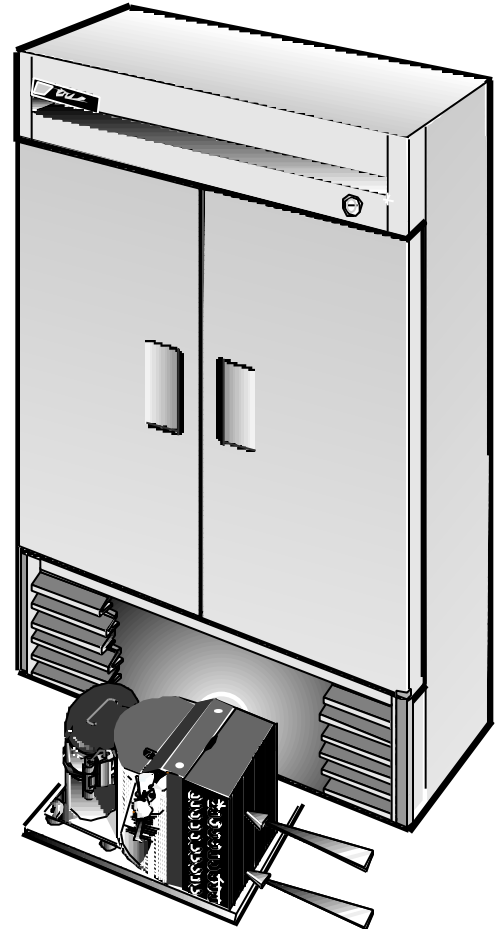
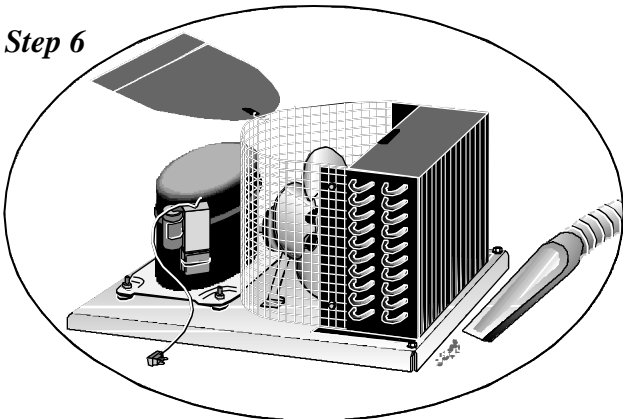

#### REQUIRED TOOLS

- Phillips Screwdriver
- Stiff Bristle Brush
- Adjustable Wrench

#### STEP 1

Disconnect power to unit.

#### STEP 2

Take off lower grill assembly by removing four (4) corner screws.

#### STEP 3

Remove bolts anchoring compressor assembly to frame rails and carefully slide out. (tube connections are flexible)

#### STEP 4

Clean off accumulated dirt from condensing coil with a stiff bristle brush.

#### STEP 5

Lift cardboard cover above fan at plastic plugs and carefully clean condenser coil and fan blades.

#### STEP 6

After brushing condenser coil vacuum dirt from coil, and interior floor.

#### STEP 7

Replace cardboard cover. Carefully slide compressor assembly back into position and replace bolts. **When reinstalling condensing unit be careful not to crimp or damage the tubing between the condensing unit and the cabinet.**

#### STEP 8

Reinstall louver assembly onto unit with appropriate fastener and clips. Tighten all screws.

#### STEP 9

Connect unit to power and check to see if compressor is running.

# **Notes**



# *REFRIGERATION SECTION*

In this section you can find information that is helpful for the customer and the service technician to help you understand how our refrigeration system works along with how to diagnose and correct any problems that might arise.



## Polyol Ester Lubricant

After exhaustive research and testing, Copeland has determined that PolyolEster (POE) lubricants provide the best combination of characteristics for use with the new generation of chlorine-free refrigerant. In addition to providing superior lubrication, POE has other advantages which increase its attractiveness for use in refrigeration.

Polyol Ester is a synthetic lubricant used primarily for jet engine lubrication. It is manufactured by numerous companies and there are various types and grades available. Therefore, it is important to recognize that all POE's are not the same.

Since POE is synthetic, it has better resistance to high temperature degradation than refrigeration mineral oils. POE is also made from more expensive base stocks making it significantly more expensive than other refrigeration oils. Furthermore, POE is compatible with common refrigerant and mineral oil. Therefore, a compressor containing the oil can be installed in a system containing HCFC's or HFC's. In short, POE provides significant flexibility in the face of changes brought on by the CFC issue.

HFC refrigerant require the use of POE for all Copeland compressors. This is necessary for two specific reasons. First, mineral oils are not readily miscible in HFC's. When using HFC's conventional oils will not return to the compressor. Secondly, the chlorine contained in CFCs and HCFCs aids in the lubricity of mineral oil.

One drawback from using POE is that they absorb moisture from the air at a much greater rate than do mineral oils. As a result, they must be handled and

packaged with much more care than conventional oils. Copeland has not tested all types of compressors or all combinations of refrigerant and con-Industry knowledge of POE must rapidly increase in order to maintain and improve expected reliability.

After conducting extensive tests for both compressor durability and reliability on more than 40 refrigerant/oil combinations, Copeland identified Mobil Oil Corporation as our preferred U.S. supplier of polyol ester oil in terms of both the oil itself and Mobil's ability to package and deliver the oil with acceptable low moisture levels. Because of its technical superiority, Copeland has approved Mobil's EAL Artic 22 CC polyol ester oil for use in our compressors.

To serve our customers, Copeland will distribute EAL Artic 22 CC to the after market through Copeland's network of 800 authorized wholesalers. The lubricant will be charged into our new production compressors whenever a polyol ester is specified. Currently, certain approved compressor models sold to OEMs are available with this oil installed during manufacture. Refrigeration service compressors charged with POE will be supplied in the near future.



## ***SERVICE CONTRACTORS***

---

***..... ATTENTION PLEASE .....***

## **SERVICE CONTRACTORS** **..... ATTENTION PLEASE .....**

This is a Tecumseh hermetic compressor specifically designed for use with environmentally friendly HFC refrigerant R404A. However, it is acceptable to use this compressor as a service replacement with R502.

The Tecumseh approved polyolester (POE) oil contained in this compressor is compatible with all internal component materials and is miscible (mixes) with R502 to effect proper oil return. Using R502 with this R404A compressor will result in very similar performance to the replaced R502 compressor. But, the following precautions should be taken.

- 1) Care must be taken to assure that most of the mineral oil is removed from the system before the new compressor is installed. Small amounts of mineral oil (up to 5%) left in the system are acceptable but 1% or less if achievable is desired.
- 2) POE oils are 100 times more hygroscopic (ability to absorb moisture) than mineral oils thus the utmost care must be taken to prevent moisture from entering the system. The compressor or system should not be left open to the atmosphere for longer than 15 minutes maximum.
- 3) The appropriate new drier provided must be installed in the system.
- 4) Established industry procedures for recovery, evacuation, refrigerant charging and leak testing should be followed.

TRUE MANUFACTURING COMPANY

## THE CAPILLARY TUBE SYSTEM

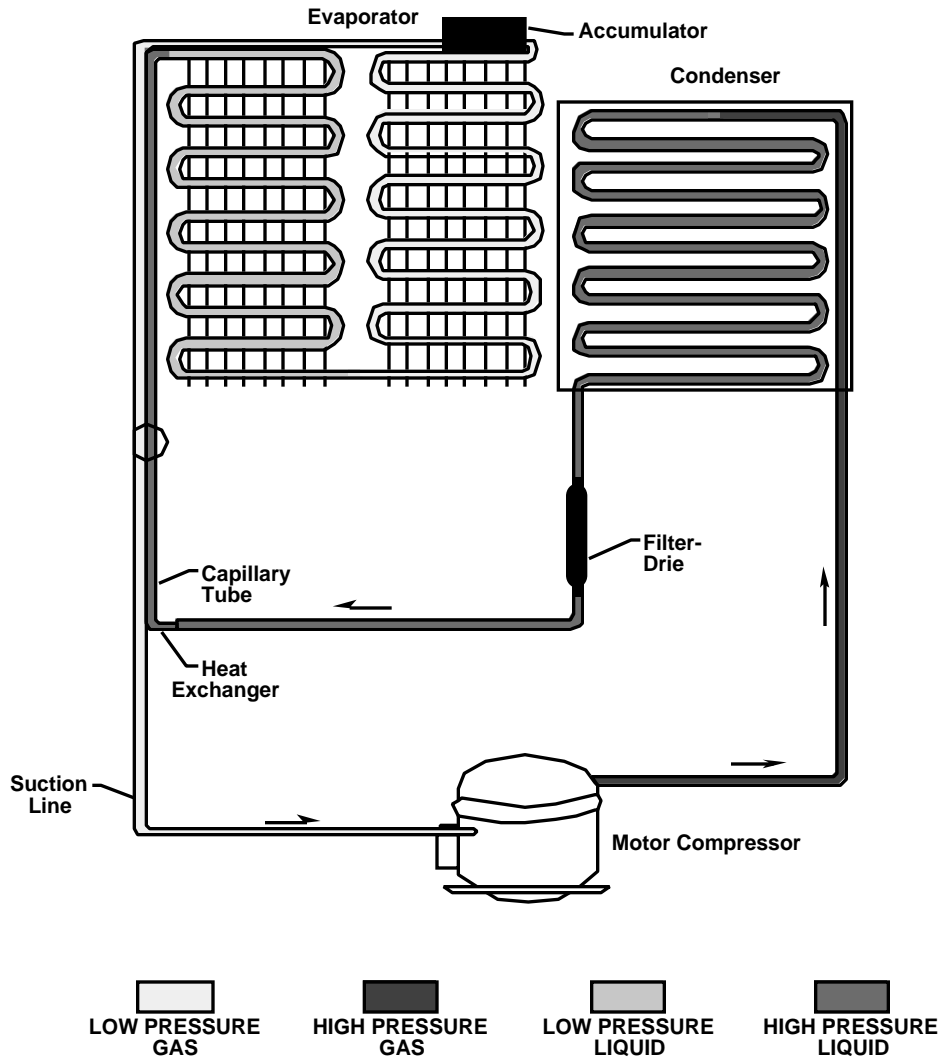

Starting at the Capillary Tube, refrigerant flows into the evaporator and changes from a liquid to a gas. As it absorbs heat, after leaving the evaporator, it flows through the accumulator. The accumulator is a part that is designed like a reservoir to allow any refrigerant, that has not changed from a liquid to a gas, space to do so before returning to the compressor. After flowing through the accumulator, refrigerant flows through the suction line as a low pressure gas into the compressor. The compressor pumps the refrigerant from a low pressure gas to a high pressure gas and forces it into the condenser. In the condenser with a fan circulating air over it the refrigerant condenses from high pressure

gas to high pressure liquid. After leaving the condenser refrigerant flow through the drier which is designed to remove any particles or moisture in the system. Refrigerant then flows through the liquid line into the capillary tube. The capillary tube is designed to allow a certain amount of refrigerant to flow through it to keep the evaporator evenly flooded. The capillary tube is taped to the suction line to cool the liquid to allow the best heat transfer. When the refrigerant enters the evaporator as a liquid, warm air from inside the cabinet is circulated through the evaporator coil and the heat from the air is then absorbed in the refrigerant.

# The Refrigeration Cycle

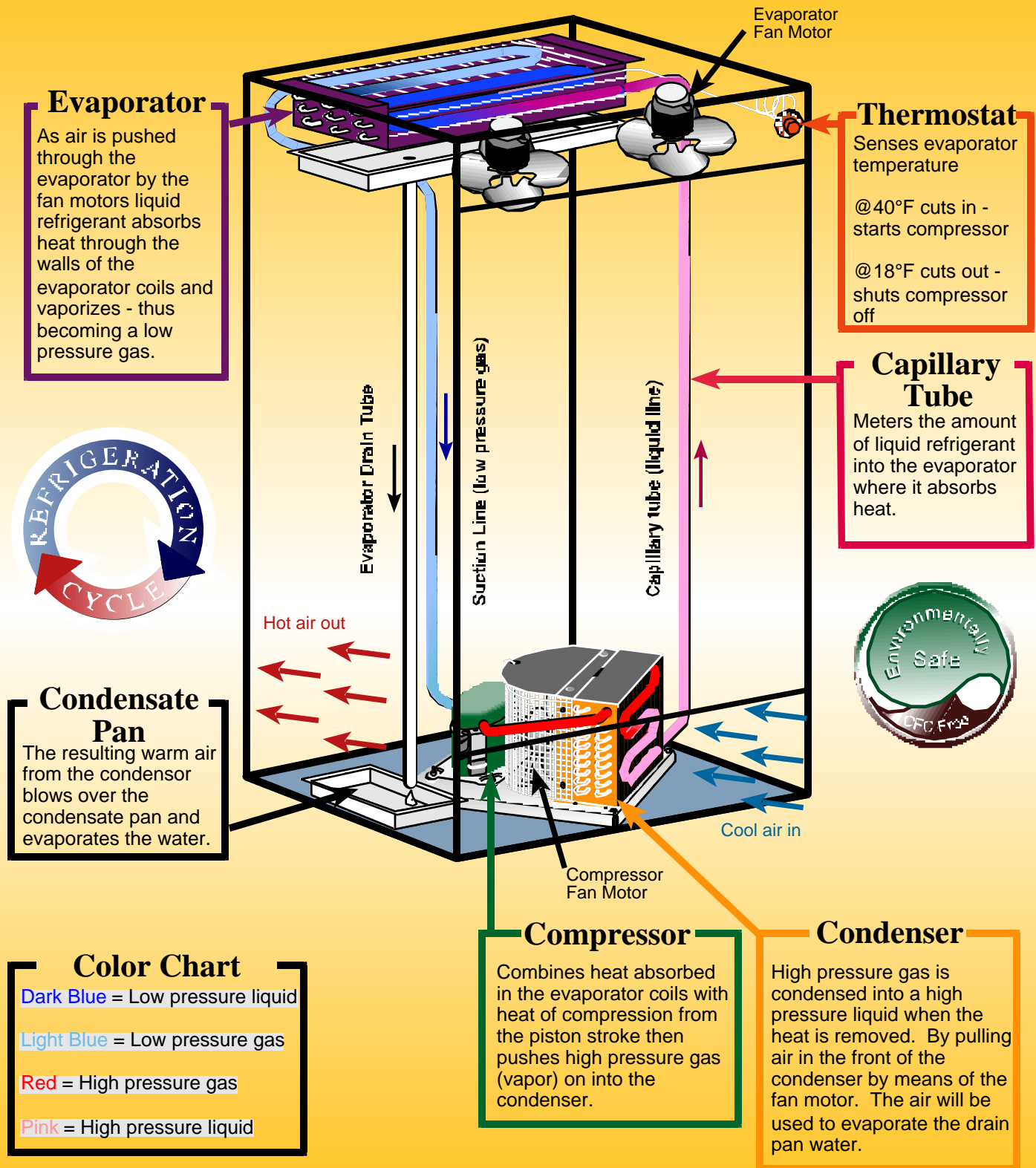



## TRUE'S REMOTE SYSTEM - HOW IT WORKS

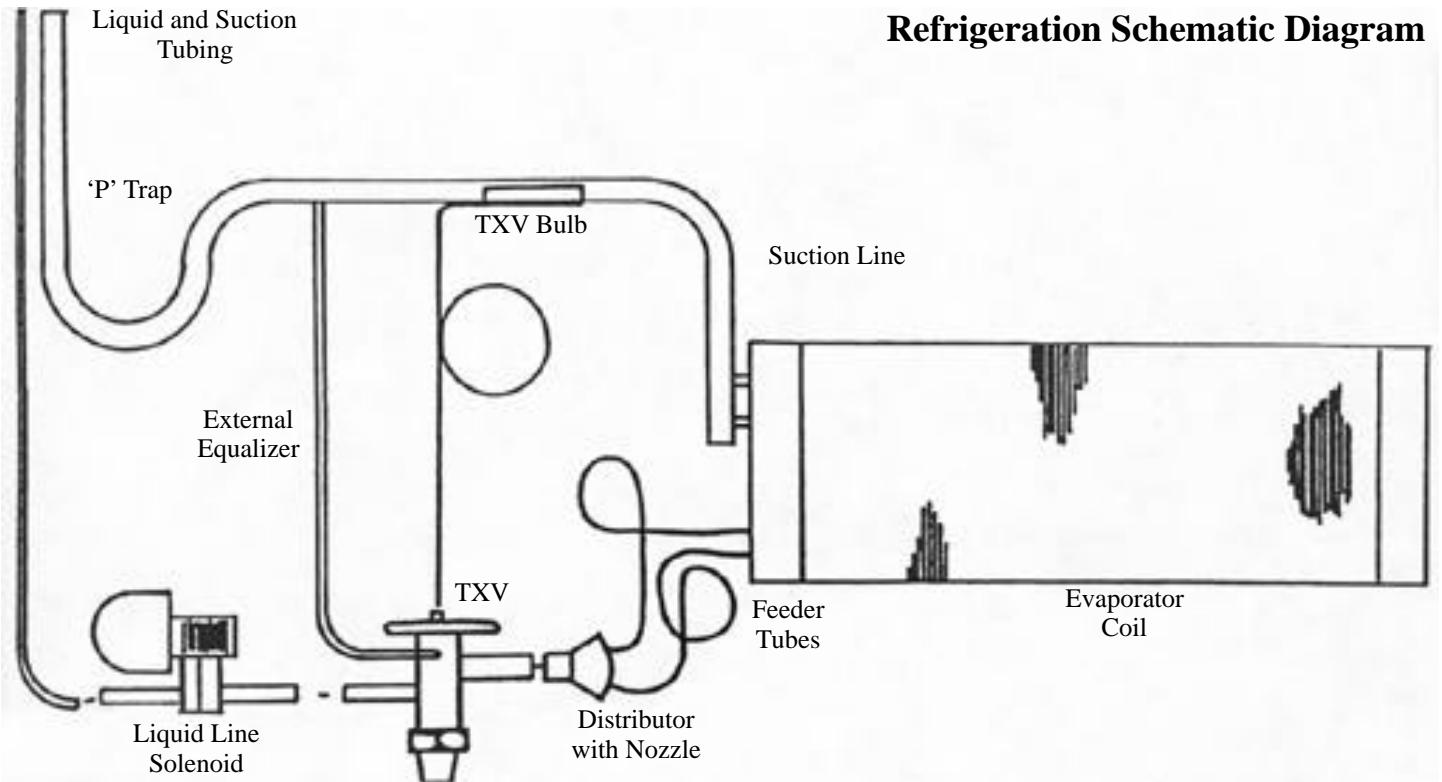

Refrigeration Schematic Diagram

The suction line will exit the evaporator coil as usual for self-contained models, except it shall include an Oil "P" trap. This is used to trap oil in low velocity suction gases at a point just prior to a vertical rise. Whether the compressor is to be located above or below the evaporator, (True does not have control over this), the suction will always have a "P" trap in case the compressor is installed overhead.

The liquid line shall enter the cabinet and go directly to the liquid line solenoid, this is a normally closed refrigerant valve which will be energized and wired in series with the thermostat. When the thermostat is closed (requires refrigeration) the solenoid will be energized to open, allowing refrigerant to pass to the "thermal expansion valve" (TXV). The TXV allows refrigerant through to the evaporator coil. If the evaporator has more than one circuit, a

distributor is used which evenly distributes refrigerant to each circuit. The TXV is made to open and close by its sensing bulb which senses suction line temperature on the other side of the evaporator. The sensing bulb has the same refrigerant that is used in the refrigeration system. When hot air passes over the evaporator coil and warms the refrigerant, the sensing bulb senses the warm condition and pushes the sensing valve open. When too much refrigerant flows into the evaporator, the sensing bulb's refrigerant cools and contracts allowing the diaphragm to ease away the needle valve, thus closing the valve.

The external equalizer is another sensing element which helps the sensing bulb to more accurately feed refrigerant. The external equalizer line must be down-stream of the TXV bulb. The TXV bulb should be insulated with corks tape.

# CFC & REFRIGERATION BASICS

## BASIC REFRIGERATION

### Control of Liquid Refrigerant Floodback To The Compressor During Operation

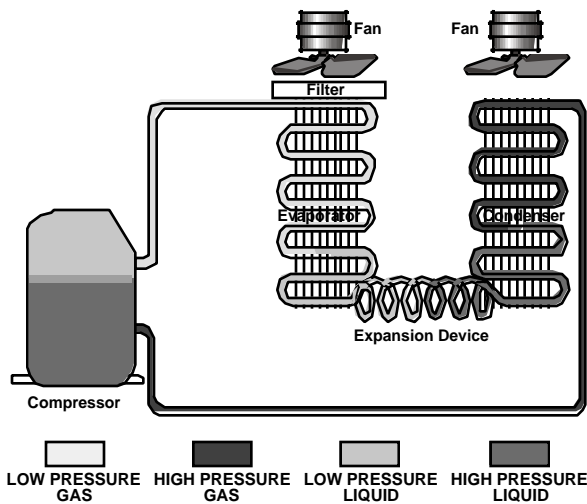

Liquid floodback during operation can be caused by fan failure, or dirty clogged filters that can reduce the heat transfer rate to such a point that the liquid refrigerant floods through, instead of vaporizing. When this situation occurs, liquid refrigerant may enter the compressor under conditions which result in separation of the oil and refrigerant. This separation may result in an accumulation of the refrigerant under the oil. Thus, when the compressor is started, the first liquid to be pumped to the bearings will probably be refrigerant, not oil. Even if this oil-refrigerant separation does not occur, the large amount of liquid refrigerant in the crankcase will instantly vaporize and boil away the oil charge when the compressor starts. Thereby leaving the compressor oil-starved for many seconds.

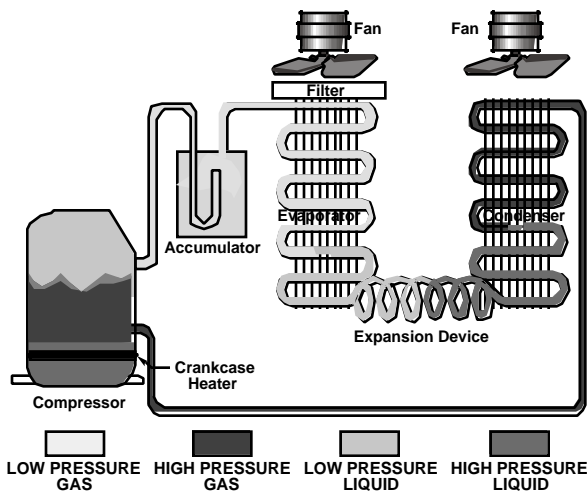

Liquid floodback can be prevented by the application of a properly designed and sized suction line accumulator. Using a totally new concept, Tecumseh engineers have designed a suction line accumulator available in eight basic sizes covering a full range of system applications and refrigerant. When properly selected based upon system charge, a Tecumseh suction line accumulator will improve compressor reliability and endurance by preventing damaging liquid refrigerant floodback.

**LIQUID REFRIGERANT ACCUMULATION IN THE COMPRESSOR CAN ALSO BE CAUSED BY LIQUID MIGRATION TO THE COMPRESSOR DURING PERIODS OF SHUTDOWN. THIS CONDITION CAN BE CONTROLLED BY THE APPLICATION OF A CRANKCASE HEATER. A SUCTION LINE ACCUMULATOR DOES NOTHING TO PREVENT LIQUID MIGRATION AND A CRANKCASE HEATER DOES NOTHING TO PREVENT LIQUID FLOODBACK. EACH WITHOUT THE OTHER IS HALF A JOB - BOTH TOGETHER PROVIDE BALANCED COMPRESSOR PROTECTION.**

# **Notes**

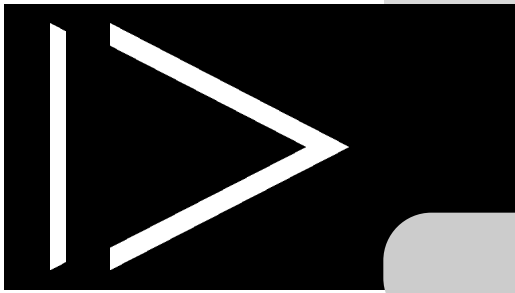

# ***GENERAL CABINET MAINTENANCE AND REPAIRS***

Using the following instructions you will be able to make cabinet exterior repairs along with other general cabinet repairs.

## ***TOP REMOVAL FOR TBB & TDD UNITS***

### **TOP REMOVAL FOR TBB & TDD UNITS**

Disconnect the power to the unit.

Locate and remove screws on the inside of the cabinet going through the evaporator housing and into the bottom of the counter top.

Locate and remove the screws securing the line set cover to the top located to the left of the evaporator housing.

Remove the two screws inside the door jamb going through the jamb into the bottom of the top. There will be two screws in each door on multiple door units.

Cut the silicone seal that runs along both ends and along the back of the unit. Silicone seal is wrapped around the front wall of multiple door units.

To remove top lift front up approximately 2-3 inches and push backward to unlock lip in back of top.

To reinstall top, carefully align the groove in the back with lip on cooler base. Slide forward, reinstall all screws and re-silicone around cabinet edge.

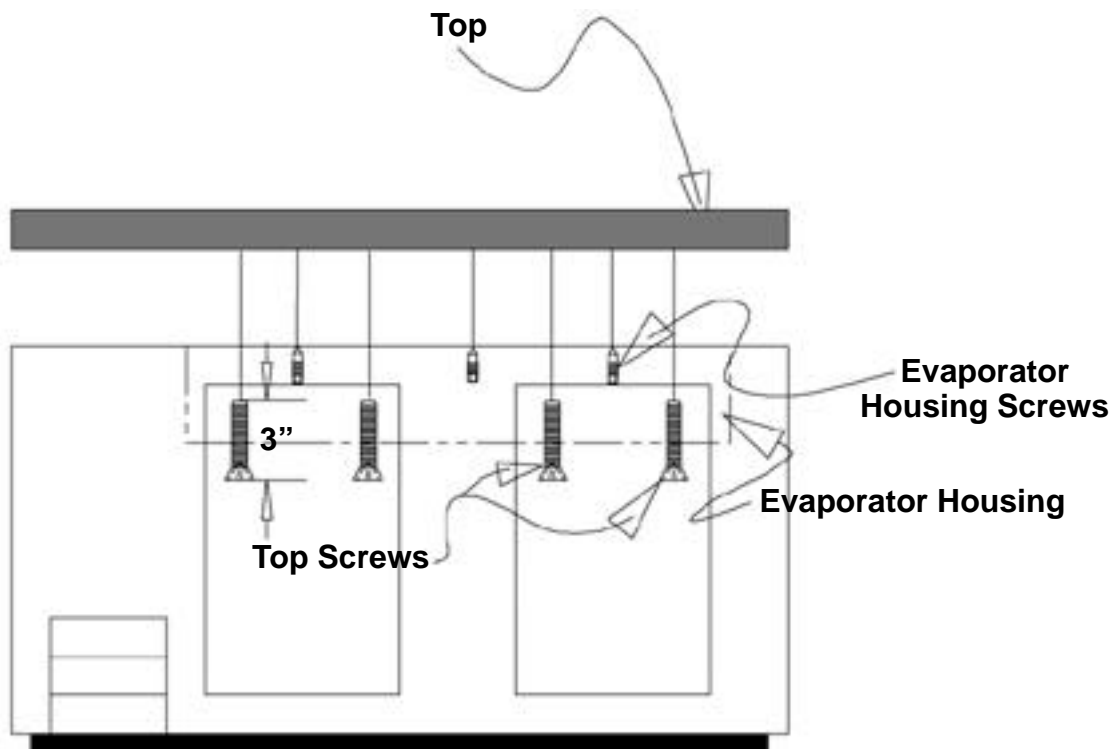

## **TOP REMOVAL FOR TD & T-GC UNITS**

### **TOP REMOVAL FOR TD & T-GC UNITS**

1. Turn unit off and remove lids.
2. Remove screws along back of cabinet top.
3. Remove screws on each side, going through lid slide rails, inside cooler.
4. Remove screws along front of top under inside ledge, also remove the two screws holding center trunion on units with more than one door.
5. Lift top to approximately 45 degrees while pushing top forward at same time. Top will lift off lip in front. **T-50-GC has heater wire looped through center trunion. Please be careful when removing top. Before reinstalling, inspect heater wire to make sure it is not damaged.**
6. To reinstall top, while holding top at 45 degree angle hook top on lip at front of cabinet and lay down while pushing backwards on top, when laid completely down press firmly on top to provide a good seal.
7. Reinstall all screws along inside of cabinet and along back of top on outside of cabinet.
8. Reinstall doors and turn unit on.

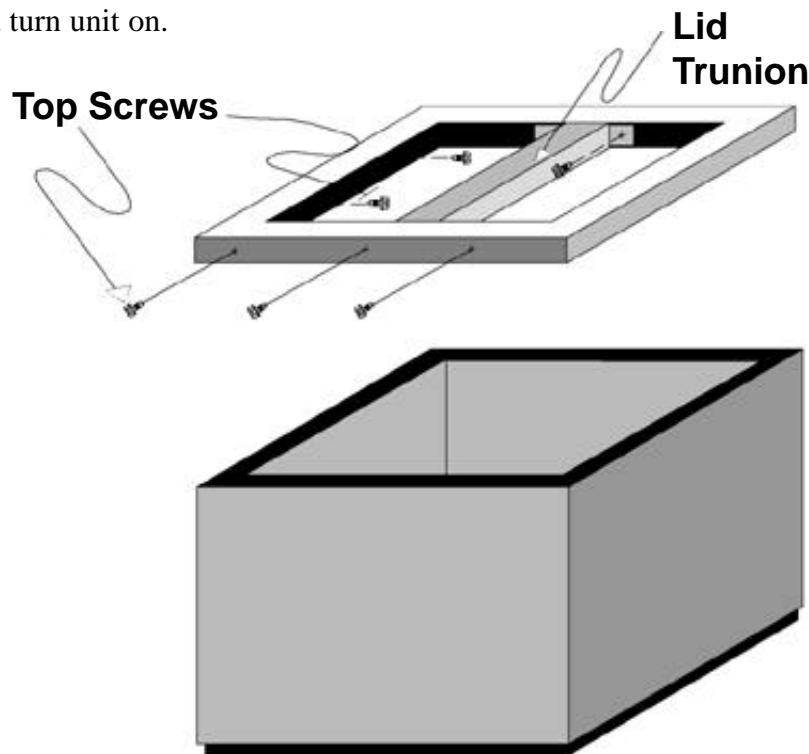

## TPP COUNTERTOP REPLACEMENT INSTRUCTIONS

1. Unscrew top door hinges from countertop and remove doors.
2. Locate & remove 2-2 3/4 inch screws in the black plastic trim in the top of each door or top drawer opening.
3. Remove front louvered grill. Remove screw from L-bracket that connects countertop to cabinet.
4. Remove screws from the following parts inside of cabinet.
  - A. Airduct, which extends from evaporator housing to far left end of cabinet. (After all screws are removed lower duct into cabinet floor).
  - B. Fan area housing (after air duct is lowered, screws connecting this housing to the countertop will be exposed, remove these screws)
5. Cut silicone seal that seals countertop to cabinet.
6. Lift up on front of countertop and push towards rear of cabinet. (Countertop slips into groove on rear of cabinet)
7. Clean all excess silicone from cabinet before reinstalling countertop.
8. To reinstall onto cabinet, sliding it to front of cabinet so it will catch in the lip on the rear of cabinet. Countertop should be flush with the rear of the cabinet when installed correctly.
9. Reinstall screws through the top of the door openings. Holes in top should align with holes in frame. Reinstall all L-brackets.
10. Reinstall screws into interior parts, first the pan area housing and then the air duct.
11. Set cabinet upright and silicone seam between countertop and cabinet.

### The following steps help to install the new counter top.

1. Follow step #8 but you will have to pre-drill 5/28" holes to reinstall 2 3/4" screws through the door/drawer opening.
2. Lay the cabinet on its back, place doors into position. Mark holes for top hinges. Pre-drill these holes with a 7/32" drill bit. Mount doors.
3. Remount doors making sure spacing between doors is even.

To install new top change steps 7, 8, and 9 to steps 1, 2, & 3.

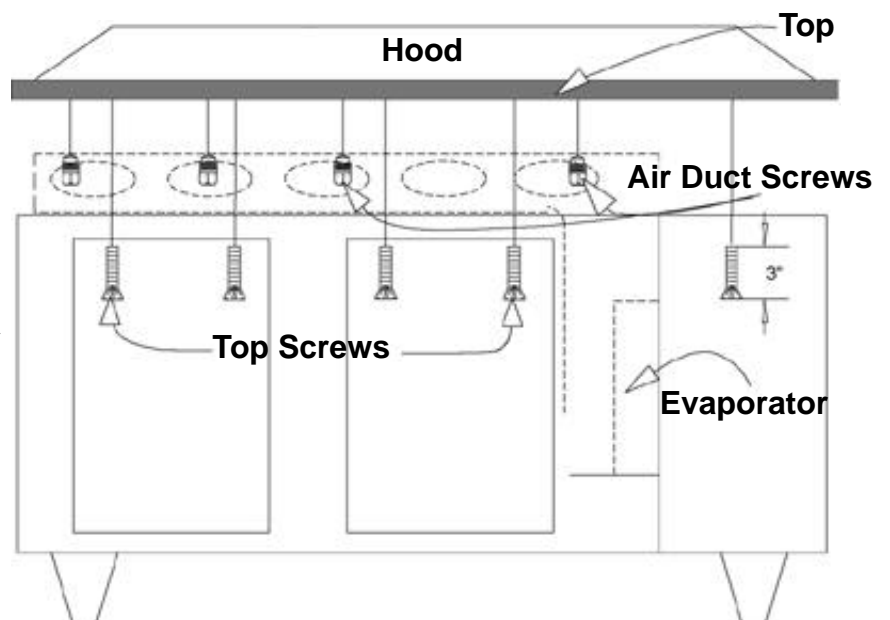

## TOP REMOVAL FOR VARIOUS COOLERS

TSSU, TWT, TUC

1. Disconnect power from cabinet.
2. Remove door(s) by removing the screws securing upper hinge to the counter top, and pull top of door towards you.
3. Locate & remove 2-2 3/4 inch screws in the black plastic trim in the top of each door or top drawer opening.
4. Cut silicone seal with razor knife on inside and outside of cabinet, break the silicone seal on both sides and along the front edge with a putty knife.
5. Lift top upward two-three inches and push backwards, this will unhook top from lip in rear edge of cabinet.
6. To install top, apply a bead of black silicone to the top of the cabinet and, hook top on lip at rear of the cabinet and pull forward, press down firmly on the top and install screws through cabinet into top.
7. Reinstall doors

### To Install New Top

1. Lay cabinet on its back & align doors with edge of cabinet. Pay attention to proper spacing of door along edge, it should be approximately 5/8". Place new silicone beads inside & out.
2. When installing a new top use 5/8" spacers at outer edge of the door and cabinet to locate door properly.
3. Push mounting plate on KEIL hinge until parallel with front of cabinet and mark center of hinge holes. Drill holes with #7 drill bit or .201 Dia. Install door on cabinet with black plastic spacer between hinge bracket and counter top and run screws into new holes and remove spacer blocks.

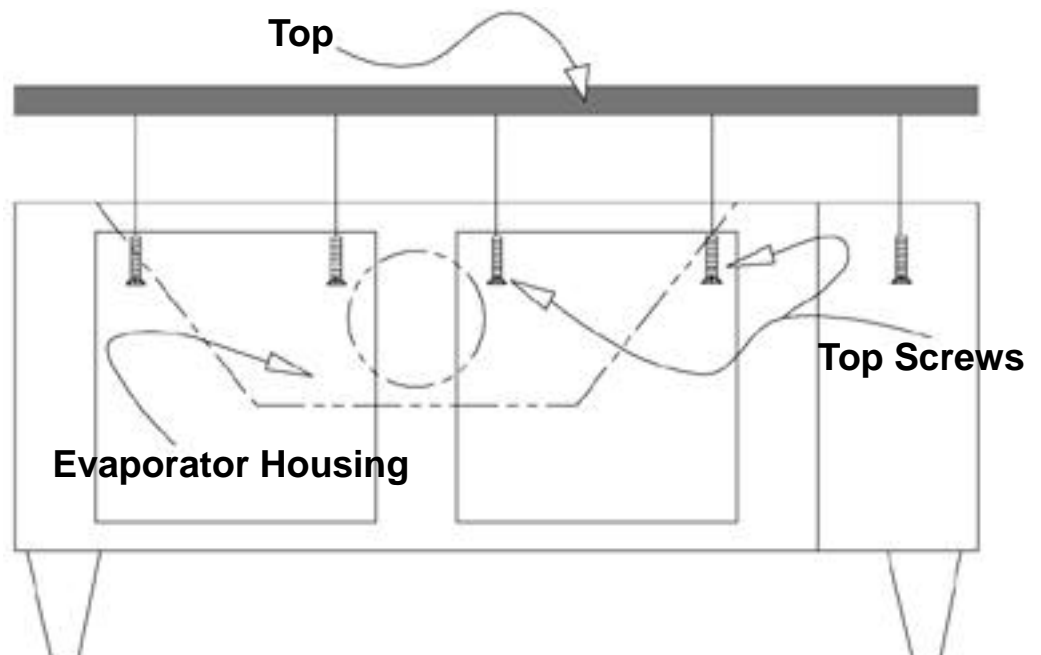



## **TOP REMOVAL FOR TRCB 50 and 79**

### **TRCB 50 and 79**

1. Disconnect the power to the unit.
2. Remove drawers.
3. Remove condensing unit grill.
4. Locate & remove 2-2 3/4 inch screws in the black plastic trim in the top of each door or top drawer opening (if necessary remove mullion).
5. Break silicone seal around countertop inside and out.
6. Lift front edge of counter top, about 10° to 15°. Push countertop toward back of cabinet to detach counter top from securing devise.
7. To install, reverse these procedures. Make sure to replace screws and apply silicone seal around edge of counter top.

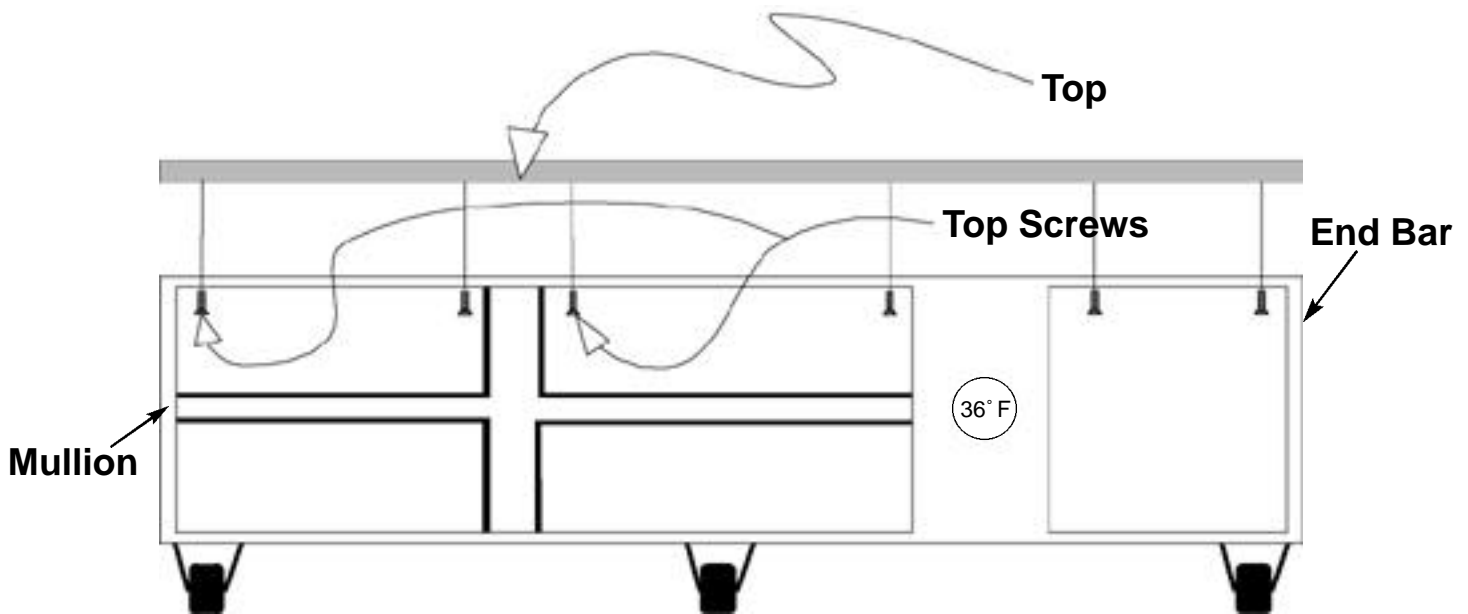

# INSTALLATION INSTRUCTION

## END CAP REPLACEMENT - T-SERIES SWING DOOR

### REQUIRED TOOLS

- Phillips Head Screwdriver
- 1/4" Hex Head Driver
- Putty Knife
- Two-Way Tape
- Rubber Mallet
- .30 drill
- Rivet Gun
- Black Silicone (optional)
- Silver/Gray Silicone Caulk (optional)

### STEP 1

Disconnect power to unit.

### STEP 2

Carefully lay cabinet on its back using 2x4's etc. to cushion and elevate from the floor.

### STEP 3

Take off lower grill assembly by removing four front corner screws. Loosen (do not remove) two screws in grill bracket on the side to receive replacement panel.

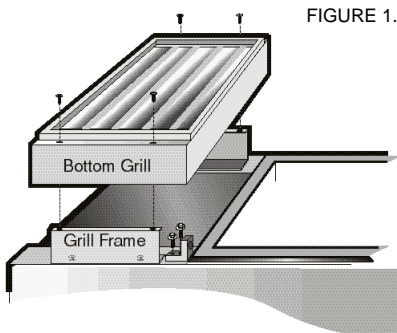

### STEP 4

Take off top grill assembly by removing three screws along the rear edge on top, two screws in the front underside and single screw on right side into top hinge bracket.

Gently lift grill and slide away from side to receive replacement panel. Be careful not to disconnect wiring to thermometer.

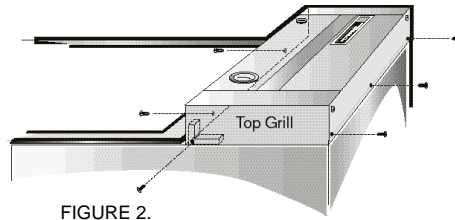

FIGURE 2.

### STEP 5

If replacement is on the hinge side of the cooler remove the door and hinges. (see instruction on page 3).

### STEP 6

Drill out rivet in stainless gasket base on right side top with a .30 bit. (no rivet on left side) and bottom.

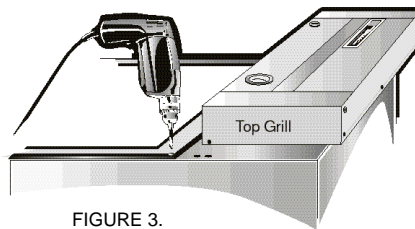

FIGURE 3.

### STEP 7

Install 5 strips of two-way tape vertically the length of the side being capped.

### STEP 8

Remove replacement panel from masonite box. (replacement panel may be used on either end) 1/2" lip faces front.

### STEP 9

Carefully bend 1 3/4" rear lip inward slightly in order to create an angle less than 90° to produce a snug fit while installing.

### STEP 10

Peel plastic film away from 1/2" front lip only.

Install panel by working the top front 1/2" lip in slot between cabinet and plastic gasket base and continue down the cabinet and under bottom grill frame. It may be necessary to use a putty knife to widen gap.

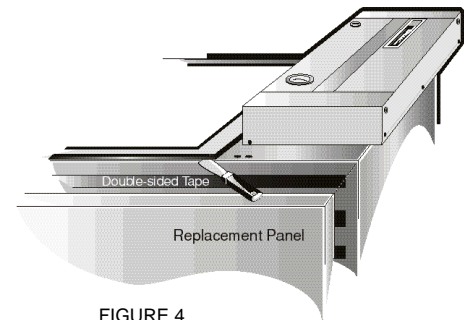

FIGURE 4.

When cap is in position gently tap folded edge with a rubber mallet until flush.

### STEP 11

Tighten screws in bottom grill frame

### STEP 12

Smooth replacement end over two sided tape and around rear edge.

Remove protective film.

# **▶ INSTALLATION INSTRUCTION**

---

## **END CAP REPLACEMENT - T-SERIES SWING DOOR (continued)**

### **STEP 13**

Drill pilot holes for rivets using .30 drill bit. Four down the front edge, and three across top and bottom edges (see figure 5).

### **STEP 14**

Install rivets.

Replace drilled out pop rivet in top right side gasket base.

### **STEP 15**

Carefully lift cabinet to upright position.

Drill 3 holes, one at top, one in middle, one at the bottom. (see figure 6)

Install rivets.

### **STEP 17**

If necessary use black silicone to create a good seal where front corner meets plastic gasket molding. Use silver/gray silicone caulk to seal rear raw edge.

### **STEP 18**

Reinstall doors and louvers.

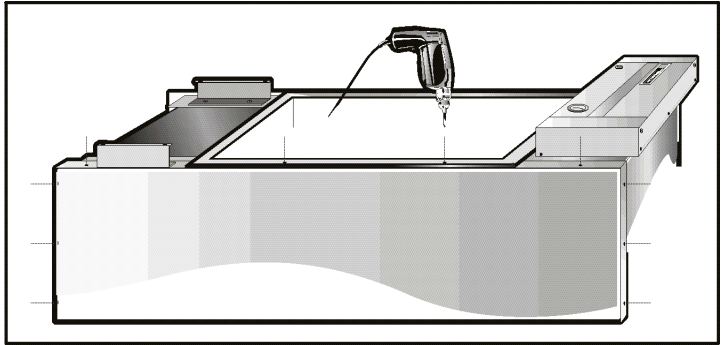

FIGURE 5.

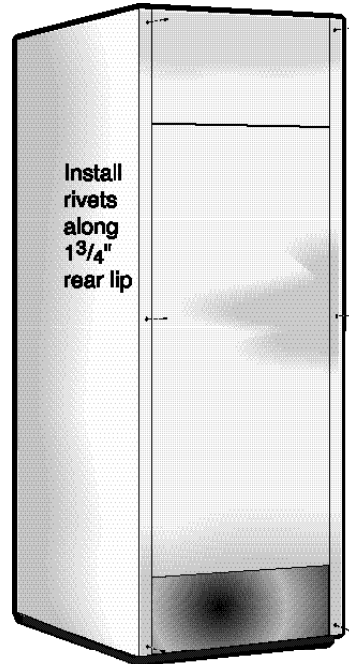
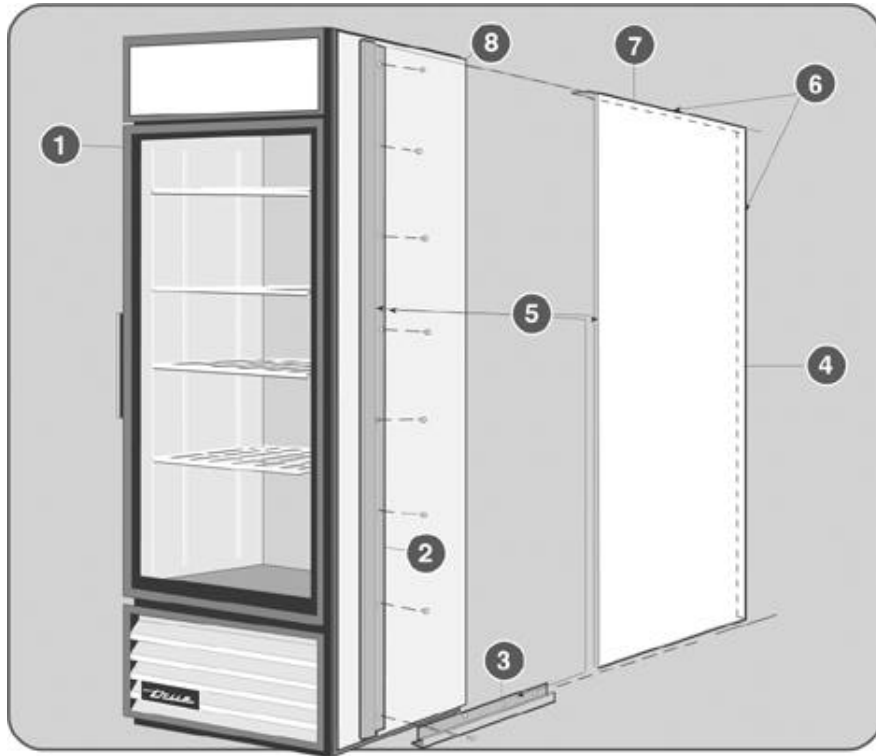

FIGURE 6.

## INSTALLATION INSTRUCTION

### SIDE PANEL REPLACEMENT - GDM SERIES



#### REQUIRED TOOLS

- 1/8" drill
- Rivet Tool
- Silicone Caulk

#### STEP 1

Make sure that both sides of the cabinet are free from dirt. Clean if necessary.

#### STEP 2

Attach the plastic extrusion to the front side corner of the cabinet side (see illustration). Use a 1/8" drill bit to drill through the extrusion and the cabinet. Use pop rivets provided to fasten extrusion. Drill and pop rivet every 8" to 10" so that the extrusion remains straight.

#### STEP 3

Attach the other plastic extrusion to the bottom side corner of the cabinet (see illustration). Drill and pop rivet every 6" to 8" so that the extrusion remains straight.

#### STEP 4

If the cabinet will be placed outdoors, the back side of the 3/4" wide flange should be silicone caulked to stop rain water from getting behind the panel.

#### STEP 5

Position and place artwork panel against cabinet so that the 3/4" wide flange is at the top and rear of the cabinet. Slide panel into the slots provided in the plastic extrusions.

#### STEP 6

Check to see that there is no gap under the top and rear 3/4" wide flange.

#### STEP 7

Drill and pop rivet the artwork panel to the cabinet using the 3/4" wide flanges provided at the rear of the cabinet and the top.

#### STEP 8

Wipe off excess silicone caulking when sealing is completed.

# INSTALLATION INSTRUCTION

## SIDE PANEL REPLACEMENT - GDM-33C-PT

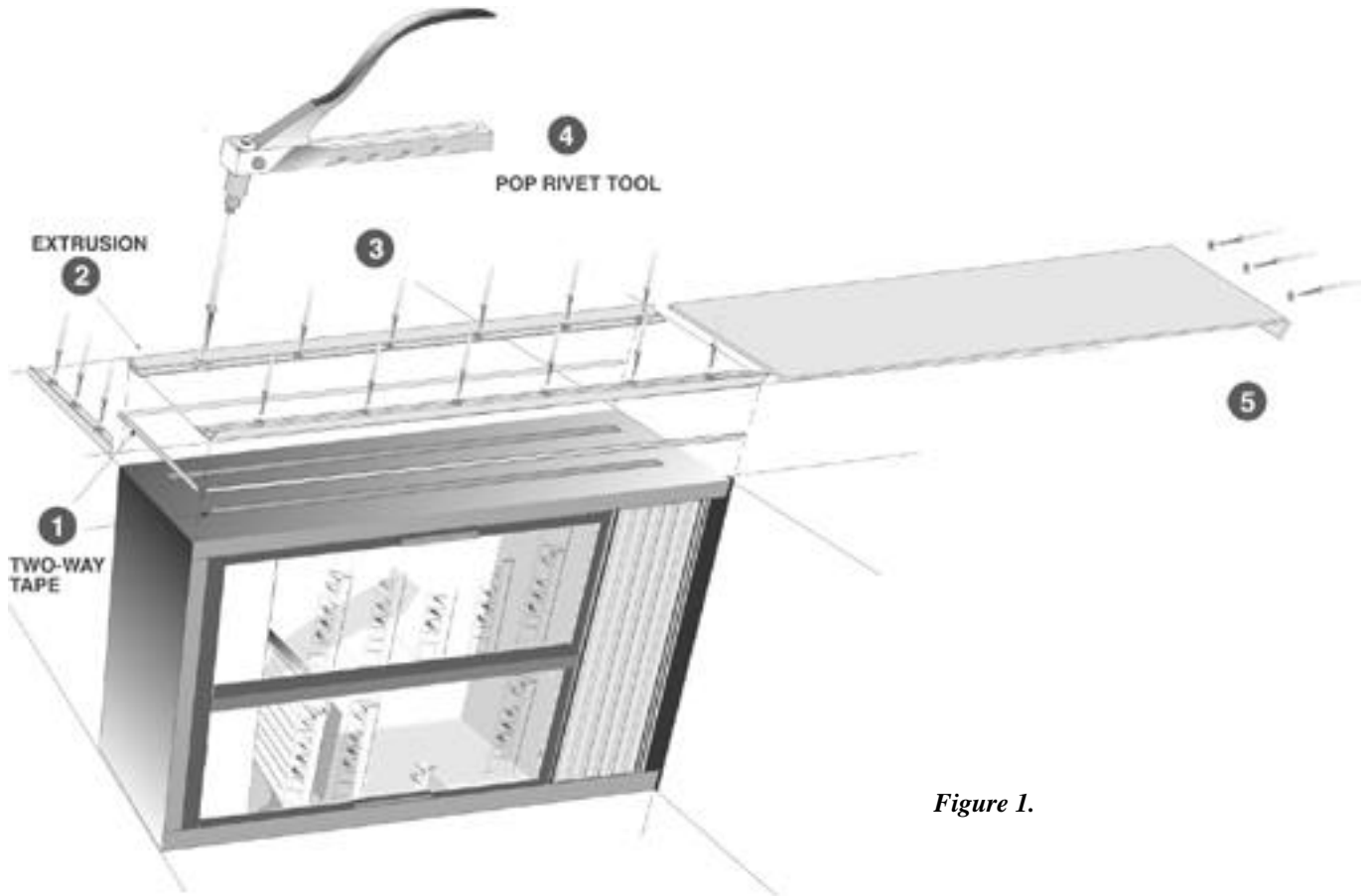

Figure 1.

The procedure listed below will enable you to create a frame around the end panel and will secure your new replacement panel.

### REQUIRED TOOLS

- 1/2" drill
- Rivet tool

#### STEP 1

Peel backing on two-way tape and attach as indicated in figure 1. Apply tape in two areas as shown. this will secure replacement panel when inserted into frame.

#### STEP 2

Peel backing away from two-way tape and secure to black plastic extrusion. Peel other side of tape and adhere extrusion to panel in the three locations indicated.

#### STEP 3

For the two longest extrusions, drill six holes. (1/2" deep), through both the extrusion and the cooler end panel. Drill three holes into the top extrusion and into the cooler top. Place at equal distance.

#### STEP 4

Anchor all three plastic extrusions with poprivets. (6 poprivets for the sides and three for the top panel.)

#### STEP 5

Slide replacement panel into newly created frame and anchor bottom flange with three poprivets.

## **INSTALLATION INSTRUCTION**

### **FLORAL CASE BAFFLE INSTALLATION**

The baffle is installed on floral cabinets to slow the velocity of the air down. This will make the flowers last longer, because the pedals do not dry out as quickly.

1. Trim a small square out of top left side of baffle to accommodate the suction line.
2. Place baffle in place and install #6 x 1/2 screws into 1/2" lip of the baffle and top of cabinet.
3. Install #6 x 1/2 screws into 1/2" lip and evaporator cover being careful not to puncture evaporator drain pan.

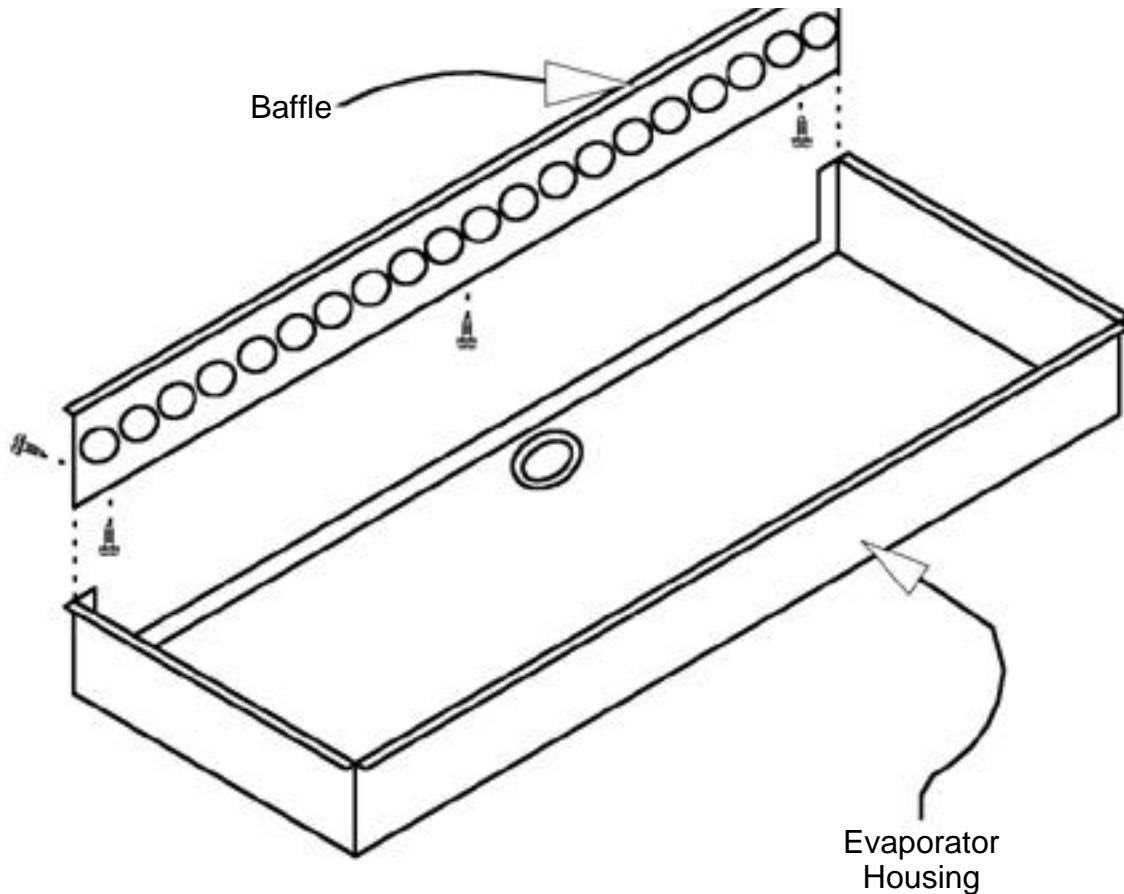

# INSTALLATION INSTRUCTION

## GDM-23FC Mirror Retrofit Kit

### REQUIRED TOOLS

- 1/16" Drill
- 1/8" - 1/4" Shim (2)
- Socket wrench

### STEP 1

Remove all products and shelving from interior of cabinet.

### STEP 2

Disconnect power to the unit.

### STEP 3

Wipe interior of cooler with a clean dry cloth to remove dirt and moisture.

Surface must be clean and dry for adhesive on extrusions (mirror support strips).

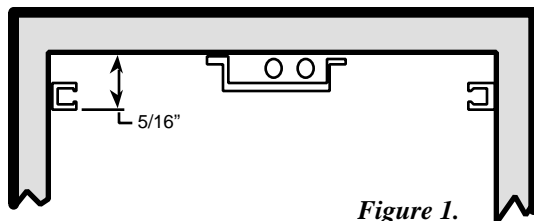

Figure 1.

### STEP 4

Measure 15/16" from rear interior wall forward and mark the side wall for the mirror support strip location. Select two shims of equal height between 1/8" - 1/4" (one for each side of the cabinet). Measure and mark the height of the shim against the side wall. Repeat on the opposite wall (see figure 1 & 3).

### STEP 5

Locate two channel extrusions (mirror support strips). Remove paper strip covering adhesive from one of the mirror support strips.

### STEP 6

Carefully secure mirror support strip against the side wall the height of the shim mark and along the mark 15/16" from the back wall.

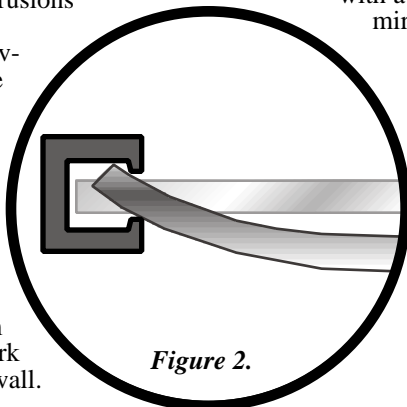

Figure 2.

Repeat on the opposite wall (adhesive backing is the only anchor for the mirror supports).

### STEP 7

Place shims on the interior floor in line to support the mirror when in position.

### STEP 8

Slip one edge of the mirror in the mirror support strip channel, bow mirror and feed into the other mirror support strip. Work until mirror fits flat inside support strips and rests on top of the floor shims (see figure 2).

### STEP 9

Locate left edge of the drain line cover at the rear of the cabinet. At the top edge of the mirror measure in 1" and down 2". Mark center point. At the bottom edge of the mirror measure in 1" from the drain line cover and up 2" from the bottom edge of the mirror. Mark center point. (see figure 3).

### NOTE

*If the drain line cover edge at the tank bottom is difficult to locate measure the distance from the side wall to the center point at the top of the mirror and use that measurement for the bottom center point.*

### STEP 10

Drill pilot holes at both center points with a 1/16" drill bit through the mirror and drain line cover.

### STEP 11

Fasten 10-16 x 1/2 hex knurled head screw (included) in both pilot holes snug against mirror.

### WARNING

*Do not over tighten screw to avoid cracking mirror.*

### STEP 12

Remove shims, replace shelving and reconnect power to cabinet.

Figure 3.

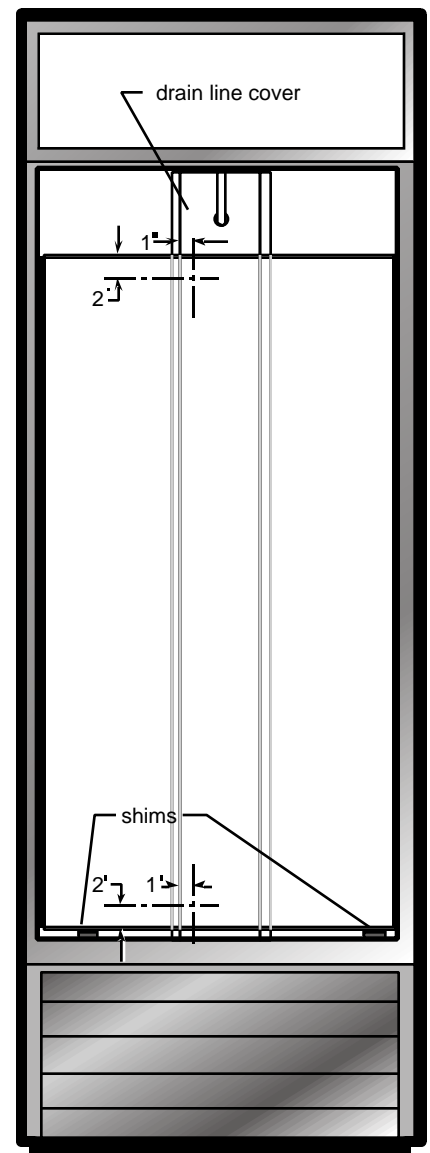

## INSTALLATION INSTRUCTION

### TWT, TUC, TSSU, and TPP PERIMETER HEATER REPLACEMENT

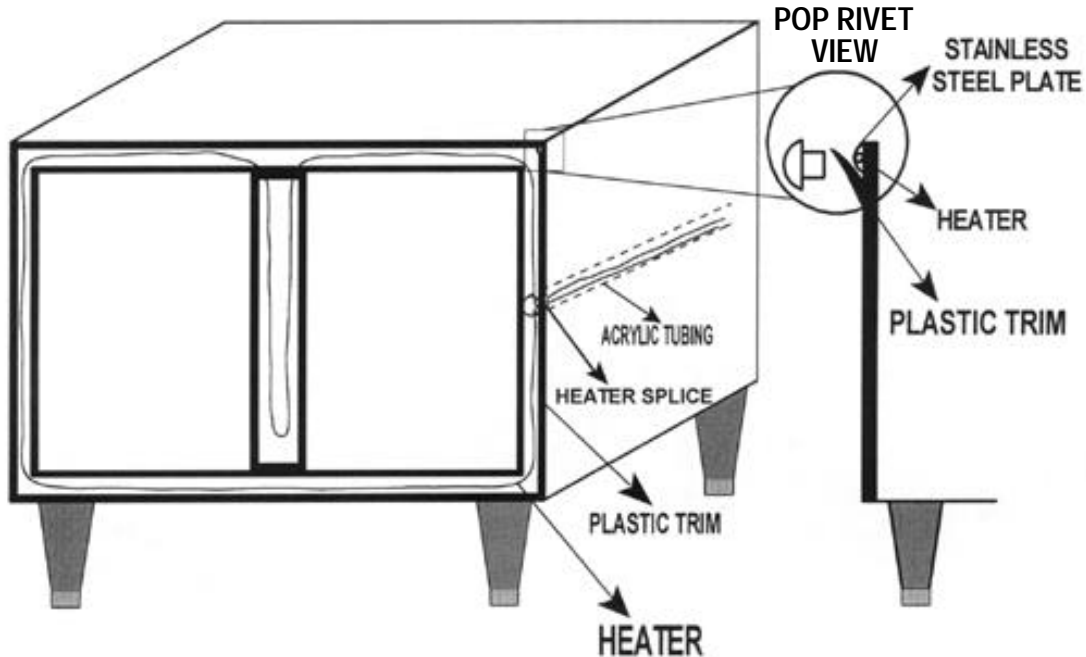

#### REQUIRED TOOLS

- Phillips Head Screwdriver
- Pop Rivet Tool
- Drill
- #30 Drill Bit

#### STEP 1

Disconnect power cord, unload contents of cabinet and lay cabinet on its back.

#### STEP 2

Remove doors by removing upper door hinges.

#### STEP 3

Drill out pop-rivet in the top right hand corner.

#### STEP 4

Lift plastic trim and slide upper stainless strip out.

#### STEP 5

Drill out pop-rivet in the bottom right corner and move vertical stainless strip up.

#### STEP 6

Lift plastic trim and slide bottom stainless strip out.

#### STEP 7

Remove bottom 3 screws on each side of mullion, remove stainless steel strip by lifting plastic trim and slide out the bottom.

#### STEP 8

Remove evaporator cover to access wiring connection of the heater wires.

#### STEP 9

Disconnect wires and remove defective heater(s) from cabinet (pay close attention to how wiring is attached around the perimeter and the mullion(s)).

#### STEP 10

Reinstall heater in the same manner. (The splice in the heater wire is to be just below the plastic trim inside the acrylic tubing). **Any section of the heater wire can not be inside of acrylic tubing.**

#### STEP 11

Insert heater wire through acrylic tubing in to the cabinet and reconnect with wire nuts.

#### STEP 12

Reinstall the stainless steel plates and pop-rivet corners.

#### STEP 13

Stand unit upright and let stand 2 to 4 hours before plugging it in.





## INSTALLATION INSTRUCTION

### GDM AND T-SERIES FREEZER PERIMETER HEATER WIRE REPLACEMENT

#### REQUIRED TOOLS

- Phillips Head Screwdriver
- Drill
- 1/8" Drill Bit

#### STEP 1

Disconnect the power supply, unload contents of cabinet and lay cabinet on its back.

#### STEP 2

Remove the lower louvered grill. Remove the stainless steel skirt around the louvered grill.

#### STEP 3

Remove the sign on the louver section above the door (s).

#### STEP 4

Remove hinges and door (s).

#### STEP 5

Drill out pop rivet on right top corner of plastic and stainless steel mullion trim. Remove the top horizontal stainless steel strip by sliding it to the right of the tracks in the plastic. Be sure to raise the corner

of the plastic trim where the pop rivet was removed so that the stainless trim slides beneath it. Drill out the two pop rivets in the top plastic trim which was hidden by the horizontal piece of stainless trim.

#### STEP 6

Remove left and right vertical stainless steel trim pieces by sliding them out of the plastic trim. Be sure to raise the top horizontal plastic trim piece so that the stainless trim passes underneath it toward the top of the cabinet.

#### STEP 7

Drill out the pop rivet that was hidden by the stainless steel trim in the lower right corner of the vertical plastic piece so that the lower vertical stainless trim slides beneath it for removal.

#### STEP 8

Disconnect heater wires in the junction box. Remove heater wire loop by unhooking at the corners where it is retained by the plastic trim pieces.

#### STEP 9

Replace inoperative heater wire loop, being sure to hook under the corners of the plastic trim as observed during disassembly.

#### STEP 10

Reverse assembly sequence to replace trim. Use the four (4) small sheet metal screws furnished with the heater wire in the same sequence as the pop rivets were removed.

#### STEP 11

Attach the heater wires to the power supply in junction box. Replace all other assemblies in reverse sequence in which they were removed.



# TD-SERIES AND GLASS CHILLERS

## TD-Series and Glass Chillers

### ***Replacement of Lid Rails, Lid Rail Trunions and Lid Gaskets***

#### ***Tools Required***

- 1/4" Nut Driver
- Pop Rivet Gun
- Drill motor
- Phillips Head Screwdriver
- Utility Knife
- Duct Tape
- #29 Drill Bit

#### ***Note:***

***For easier installation of new lid rails and lid trunions, it's best to remove the top from the cabinet.***

#### ***Note:***

***When changing out lid rails or lid trunions on a T-50-GC, the trunion has a mullion heater looped through it.***

#### \_\_\_\_\_ **STEP 1** \_\_\_\_\_

Disconnect electrical power to cabinet.

#### \_\_\_\_\_ **STEP 2** \_\_\_\_\_

Remove top from cabinet (See Top Removal instructions for TD & T-GC on page 30).

#### \_\_\_\_\_ **STEP 3** \_\_\_\_\_

Once top is removed, turn top upside down and remove galva-

nized air deflector. This will expose the hidden screws holding trunions and lid rails to top and any tape on the back side of the lid rails. This will need to be cut or removed.

#### \_\_\_\_\_ **STEP 4** \_\_\_\_\_

Remove old lid rails and lid trunions. Note how the lid rails have a slot in the top edge which slides into the inside edge of the stainless steel top. Once you have new lid rails in place, you will need to re-tape to secure them until top is re-installed on cabinet. Install new lid trunions and any lid gaskets that may need replacing.

#### \_\_\_\_\_ **STEP 5** \_\_\_\_\_

Re-install air deflector to top.

#### \_\_\_\_\_ **STEP 6** \_\_\_\_\_

Re-install top to cabinet (See Top Removal instructions for procedure).

#### \_\_\_\_\_ **STEP 7** \_\_\_\_\_

Once top has been installed, you will need to install the new lid rail covers. These will insert into the lid rails (sides only) and trunions. You will need to use your drill motor and a #29 drill bit, drill 2 holes about 12" apart in each lid rail to install the 1/8"

aluminum rivets (2 each) in each lid rail cover.

#### ***Note:***

***Be sure to use only aluminum rivets as steel may rust.***

# INSTALLATION INSTRUCTION

## TEMPERATURE CONTROL REPLACEMENT

(For Cabinets With Larger Than 1/3 H.P. Compressors)

### WARNING:

Failure to disconnect power to the unit may result in electrocution to field personnel.

#### Qualified Repair Personnel:

These repairs should be performed by a qualified service technician.

#### Required Tools:

- Phillips-head Bit
- 1/4" Nut Driver Bit
- Wire Cutters
- Drill
- Needle-Nose Pliers
- Wire Strippers
- Crimping Tool
- Voltmeter
- Plastic Mallet or Hammer
- Slotted Screw Driver

#### Contents of Relay Kit:

- Relay (and mounting screws)
- Relay Shield (and mounting screws)
- (4) Relay wires: 2 blacks, 1 pink, 1 white with insulated female spade connectors on one end.
- Grommet
- (4) Sta-con connectors
- New temperature control
- Instructions

### STEP 1

#### Removing Power:

- A. Disconnect power to the unit.

### STEP 2

#### (Slide Door)

#### Remove Louvered Grill:

- A. To remove grill, loosen upper screw on each end of grill and remove lower screws. Gently swing grill forward and up.



Figure 1. Removing louvered grill (slide door model)

#### (Swing Door)

#### Remove Louvered Grill:

- A. Remove screws as indicated by arrows.

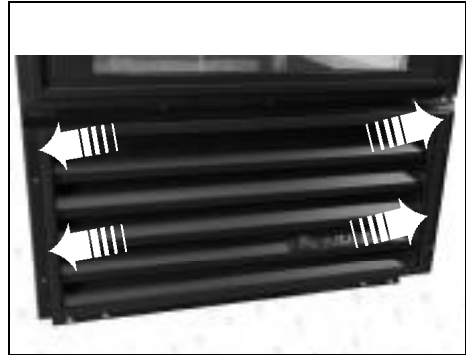

Figure 1A. Removing louvered grill (swing door model)

### STEP 3

#### Accessing Wire Connections:

- A. Remove ballast box cover by backing out two hex head screws. (See Figure 2).

**NOTE:** Wiring diagram is positioned on inside cover.

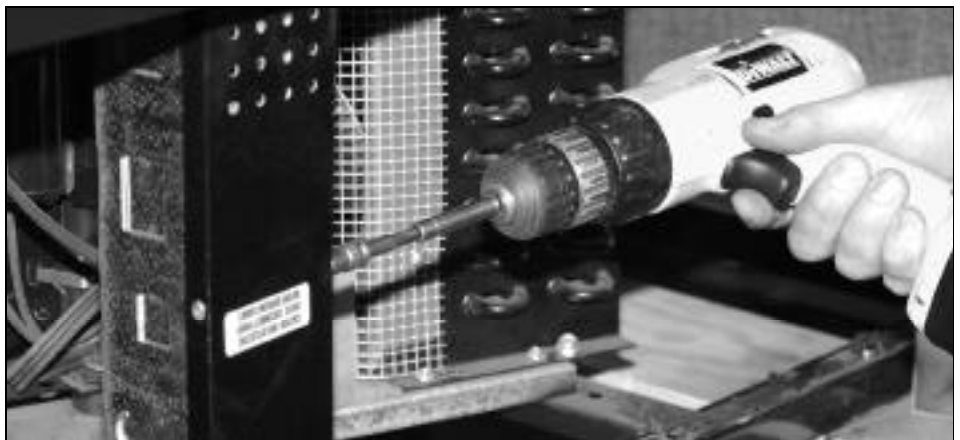

Figure 2. Removing ballast box cover

## ▶ INSTALLATION INSTRUCTION

### TEMPERATURE CONTROL REPLACEMENT CONTINUED.....

#### STEP 4

##### Relay Connection Mounting:

A. With slotted screw driver and plastic mallet or hammer, drive out knock out positioned on left side of ballast box. (See Figure 3).



Figure 3. Driving out knockout

B. Install the supplied grommet\* into the knockout hole. (See Figure 4).



Figure 4. Installing the grommet

C. Mount relay to underside of unit on the left side of ballast box, and 3/4" back from the front edge of the underside.

**NOTE:** Mount relay next to the ballast box, so that when the relay shield is installed it covers the relay and all exposed wiring.

Relay should be anchored with two self-tapping screws, (supplied in kit), as pictured in Figure 5.



Figure 5. Anchoring relay

## INSTALLATION INSTRUCTION

### TEMPERATURE CONTROL REPLACEMENT CONTINUED.....

#### STEP 5

##### Relay Temperature Control Wiring:

A. Connect the wires included in kit to the relay as follows:

1. Connect one black wire to one of the normally open contacts of the relay.
2. Connect the other black wire to the other normally open contact on the relay.
3. Connect the pink wire to one side of the relay coil.
4. Connect the white wire to the other side of the relay coil.

**NOTE:** Each relay has a wiring diagram on the side of it.

(See Figure 6).

B. Feed wires into the ballast box through the knockout. (See Figure 7).

C. Using the Sta-Con connectors in the relay kit, make the following connections inside the ballast box:

1. Locate the pink wire coming from the temperature control and connecting to the black compressor receptacle wire. Cut this connection and connect this pink wire from the temp control to the pink wire going to the relay.

2. Connect one black wire on relay to the black wire cut from the compressor receptacle.

3. Connect the white wire coming from the relay to the white wire bundle that is connected to the white on the main power cord.

4. Connect one black wire to the black wire bundle that is connected to the outgoing terminal on the main power switch located on the ballast box.

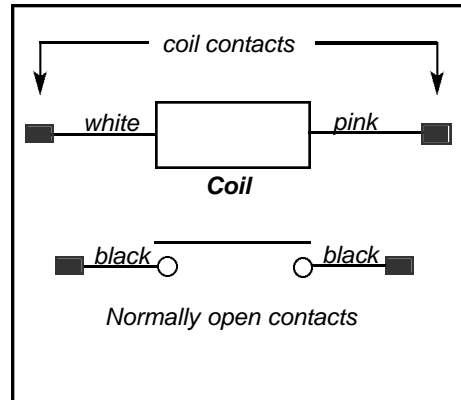

Figure 6. Relay Wiring Diagram



Figure 7. Routing relay wires

## INSTALLATION INSTRUCTION

### TEMPERATURE CONTROL REPLACEMENT CONTINUED.....

#### STEP 6

Replace existing temperature control with new Danfoss control in repair kit:

(See Figure 8).

- A. Connect one pink wire from old control to double terminal #4 on new temperature control.
  - B. Place the plastic-coated spade clip on secondary #4 terminal.
  - C. Connect other pink wire from old control to terminal #3 on new Danfoss temperature control.
- (See Figure 8 & 9).

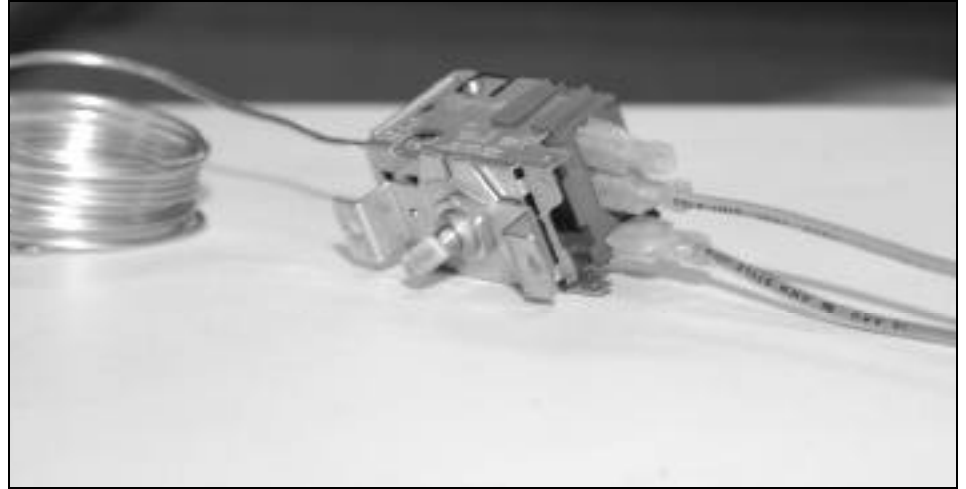

Figure 8. Temperature Control Leads

#### STEP 7

Anchor the Relay Shield:

(See Figure 10).

- A. Secure the new relay by attaching the relay shield.
- B. Relay shield includes two self-tapping screws. When installing shield, place shield in position to cover relay and all exposed wiring.

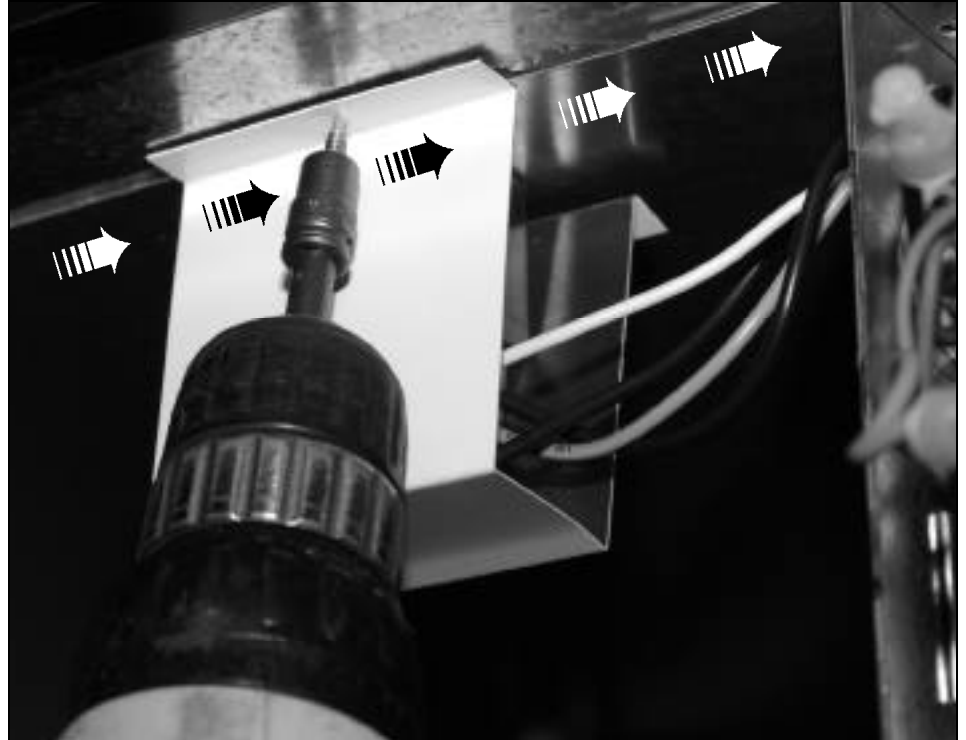

Figure 10. Anchoring Relay Shield



# INSTALLATION INSTRUCTION

---

## TEMPERATURE CONTROL REPLACEMENT CONTINUED.....

\_\_\_\_\_ **STEP 8** \_\_\_\_\_

Unplug the cooler

\_\_\_\_\_ **STEP 9** \_\_\_\_\_

**Checking Relay Operation:**

A. Unplug the condensing unit from the compressor receptacle ( located on the ballast box).

B. Turn the new control to the “0”, (zero), position by aligning the zero indication on control knob with the arrow stamped into the evaporator housing. Ensure that control is off by listening for an audible click. This will indicate an off position.

C. Plug voltmeter into compressor receptacle.

D. Plug cabinet into power source.

**Securing Ballast Box:**

A. Reinstall ballast box cover.

B. Anchor cover with two screws.

F. Check voltage at compressor receptacle. Voltage should equal voltage at wall outlet.

G. If voltage is correct, turn temperature control to “0”, (zero).

H. Plug condensing unit cord back into the compressor receptacle.

\_\_\_\_\_ **STEP 10** \_\_\_\_\_

**Replacing Louvered Grill:**

A. Reinstall grill by reversing earlier procedure.

\_\_\_\_\_ **STEP 11** \_\_\_\_\_

**Re-connect Power Cord.**

\_\_\_\_\_ **STEP 12** \_\_\_\_\_

**Return Temp Control to normal setting, and check cabinet operation.**

# INSTALLATION INSTRUCTION

## TEMPERATURE CONTROL CHANGE-OUT - GDM

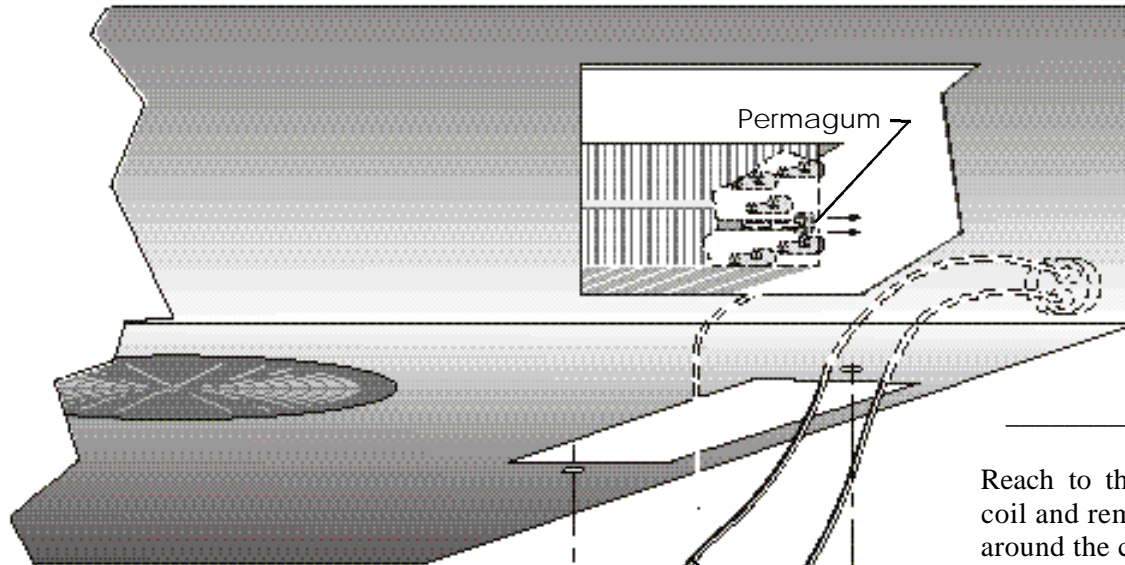

Figure 1.

### REQUIRED TOOLS

- Phillips Head Screwdriver
- Hex Head Driver

**STEP 1**  
Unplug the cooler

**STEP 2**  
Turn the temperature control to the "OFF" position ("0").

**STEP 3**  
Remove the black control knob on the temperature control. (It pulls off.)

**STEP 4**  
Remove the screws that secure the mounting plate to the evaporator top. Item "A".

**STEP 5**  
Remove the two screws that hold the control to the mounting plate. Item "B".

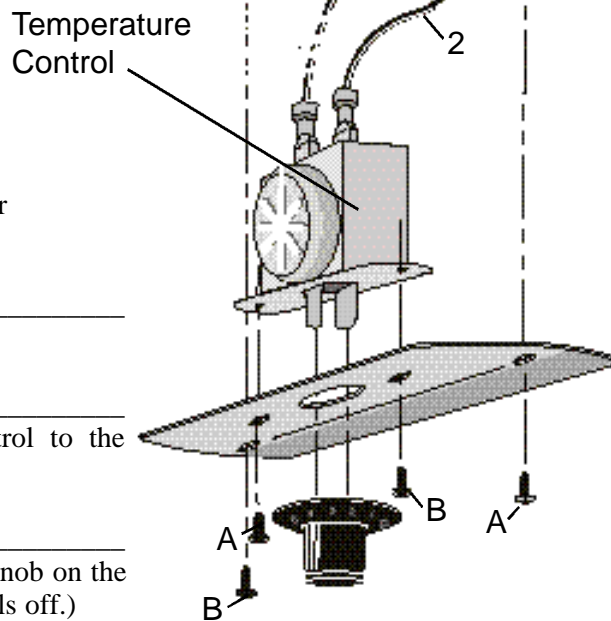

**NOTE:**  
*If it becomes necessary to remove the housing be sure to tape off any interior panel at risk of being scratched.*

**STEP 6**  
Disconnect the two wires from the temperature control. Items 1 and 2.

### STEP 7

Reach to the side of the evaporator coil and remove the permagum from around the control bulb. Completely remove the control bulb from the sleeve, and pull straight out after removing the permagum.

### Danfoss Temperature Control Change Out.

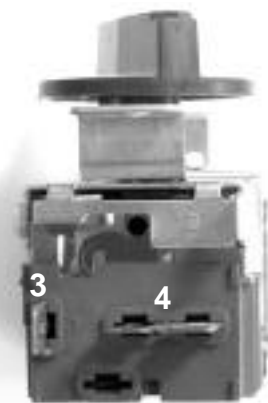

Figure 9.

Connect one wire to terminal #3 and the other wire to terminal #4.

**Note:** Spare terminal #4 should be covered with insulated female connector sent with new control.



# INSTALLATION INSTRUCTION

## TEMPERATURE CONTROL CHANGE-OUT - GDM AND T-SERIES

### Installing The New Control

#### REQUIRED TOOLS

- Permagem
- Phillips Head Screwdriver
- Hex Head Driver

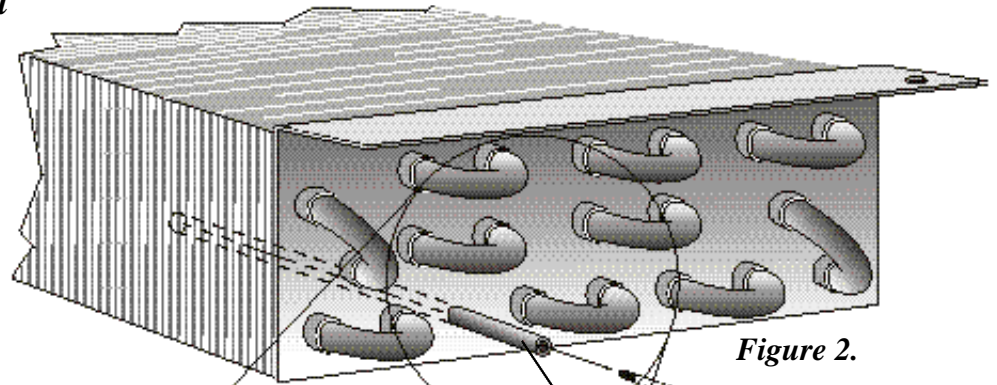

Figure 2.

#### STEP 1

Insert the control bulb into the copper sleeve. Before insertion, be sure there are no kinks in line. (figure 2)

#### STEP 2

#### IMPORTANT!

Seal the end of the sleeve with permagem to keep moisture out. (figure 3)

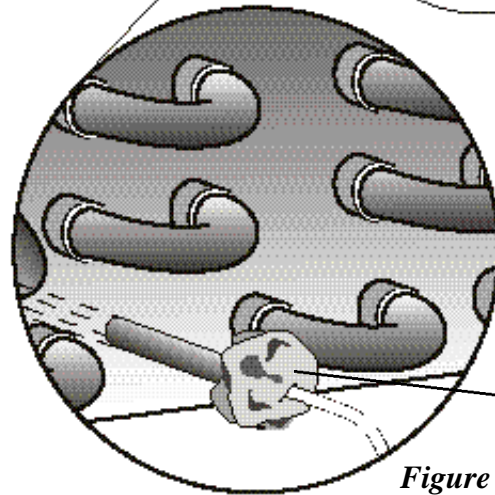

Figure 3.

#### STEP 3

Connect the two wires to the new temperature control.

#### STEP 4

Fasten the control onto the mounting plate with two screws. Item A.

#### STEP 5

Fasten the mounting plate to the cooler with two screws. Item B.

#### STEP 6

Replace black control knob and turn the control to the #5 setting.

#### STEP 7

Plug the Cooler in.

#### NOTE:

*If it becomes necessary to remove the housing be sure to tape off any interior panel at risk of being scratched.*

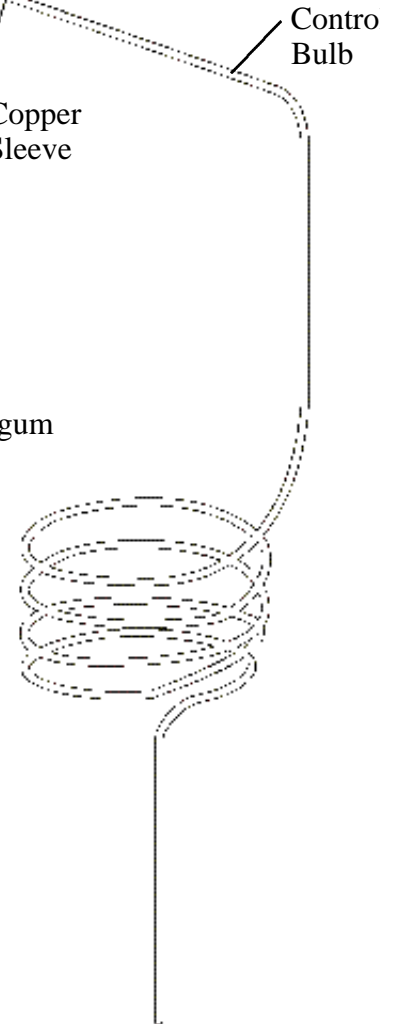

#### CAUTION

*Wait at least 12 hours before re-adjusting control. This allows the Cooler to stabilize cycle.*

## INSTALLATION INSTRUCTION

### Replacing Temperature Controls in GDM-7, GDM-10, and GDM-12 Models

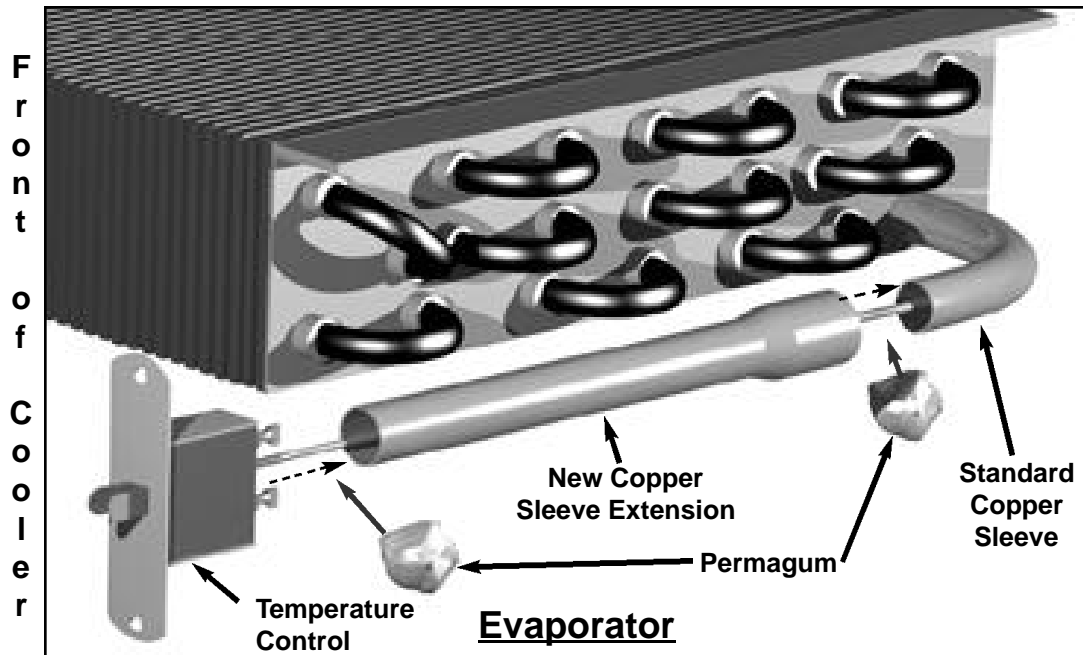

#### STEP 1

Unplug Cooler and turn temperature control to "off" (0°) position.

#### STEP 2

Pull off the black control knob from the control.

#### STEP 3

Remove the mounting plate from the evaporator housing.

#### STEP 4

Remove the temperature control from the plate and disconnect the 2 wires.

#### STEP 5

Remove the lamp from the front of the cooler and remove the front panel.

#### STEP 6

Reach in to the side of the evaporator coil and remove the **permagum** from around the control bulb. Then remove the old thermostat control bulb from the sleeve completely.

#### STEP 7

Insert the new thermostat control bulb into the new copper **sleeve extension** until about 1/2 inch protrudes from the swaged end. Using a low temperature lubricant on the control bulb is advisable.

#### STEP 8

Using the protruding end of the control bulb as a guide, insert it into the copper sleeve (elbow) in the rear of the evaporator. Then push the sleeve extension over the end of the elbow to lock the two tubes together.

#### STEP 9

Gently push the control bulb through the joined sleeves in 1-2 inch increments until it reaches the end inside the evaporator, taking care not to kink the line.

#### STEP 10

Seal both ends of the new control sleeve with permagum to keep moisture out.

#### STEP 11

Remove the mounting plate from the evaporator housing. Connect the 2 wires to the new control, the control to the mounting plate, the plate to the cooler, and replace the control knob.

#### STEP 12

Turn the control knob to the #5 setting.

#### STEP 13

Reassemble front of cooler and plug it in.

# INSTALLATION INSTRUCTION

## SURGE PROTECTOR'S FOR THE GDM-SERIES

### SURGE PROTECTOR INSTALLATION

This instruction is *True's* recommended procedure for installing surge protection - part no. VD S16P.



### REMOVING POWER

#### STEP 1

Disconnect power before installing surge protector.

### REQUIRED TOOLS

- Multimeter
- Adjustable Wrench
- Phillips Screwdriver
- Wire Strippers
- Wire Cutters
- Crimper

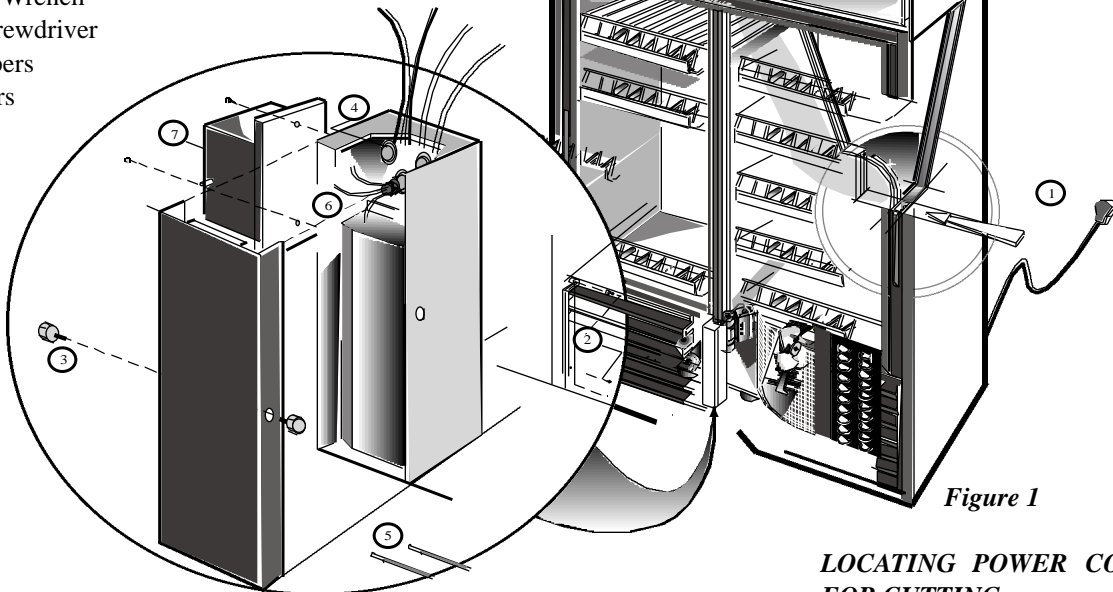

Figure 1

### LOUVERED GRILL REMOVAL

#### STEP 2

Remove louvered grill by removing the four phillips-head screws as shown in Figure 1, # 2.

### BALLAST BOX ACCESS

#### STEP 3

Remove ballast box cover by un-screwing two 1/4" hexhead screws, center-positioned on both sides of cover plate. See Figure 1, #3.

### KNOCKOUT LOCATION AND BUSHING INSTALLATION

#### STEP 4

Locate 5/8" knockout positioned on the inside, upper left, of ballast box. Figure 1, # 4.

### CREATING WIRE CONNECTION FOR SURGE PROTECTOR

#### STEP 5

#### NOTE

*Installer will need to provide #16 wiring for splicing.*

From this installer supplied wiring, cut two, pink, 15" pieces and strip both ends 1/2" from ends. On one end of each wire, crimp on a 1/4", quick-connect, insulated, slip-on connector.

### LOCATING POWER CORD WIRING FOR CUTTING

#### STEP 6

The power cord wiring is routed through the middle knockout in the cluster of three knockouts in the upper inside of the ballast box. See Figure 1, #6.

# INSTALLATION INSTRUCTION

## SURGE PROTECTOR'S FOR THE GDM-SERIES ...Continued

### LOCATING POWER CORD WIRING FOR CUTTING (cont.)

#### ...STEP 6

Locate the junction of tan, pink and black wires coming from power cord area. See figure 1 and Figure 2. If cabinet is supplied with a European style cord, the power cord, black, wire will be brown.

At this junction, cut the pink wire several inches from the junction. Strip each end of wire 1/2". See figure 2.

### ATTACHING THE SURGE PROTECTOR TO THE BALLAST BOX

#### STEP 7

Position the surge protector on left side of ballast box toward back edge. Allow for cover clearance. See Figure 1. # 7

Using self-drilling screws, attach the surge protector on the ballast box, as illustrated in Figure 1, step # 7.

#### NOTE

For GDM-23 mount surge protector below flooring.

### SPlicing INTERCONNECTING WIRING TO SURGE PROTECTOR

#### STEP 8

- Route all interconnecting wires through newly created knockout hole. See Figure 2.
- Take one pre-cut 15" pink wire, and locating pink wire still connected to wire junction, connect these together with an in-line splice or butt splice. On surge protector, connect another end of pink wire to "LINE IN", (marked on surge protector).

- Next, locate other loose pink wire in ballast box, connect the remaining pink wire with in-line splice or butt connector.
- On surge protector, connect other end of pink wire to "LINE OUT".
- Now create a 15" long white wire. Strip both ends 1/2". On one end put 1/4" quick-connect insulated slip on connector.
- Locate junction of white wires in ballast box. (if cabinet is supplied with a European style cord, this wire will be blue.)
- Cut end connector off junction, re-strip wires and add white wire. Re-crimp the connection using a large closed-end connector.
- On surge protector, connect other end of white wire to "NEUTRAL".

### ENCLOSING WIRING AND UNIT START-UP

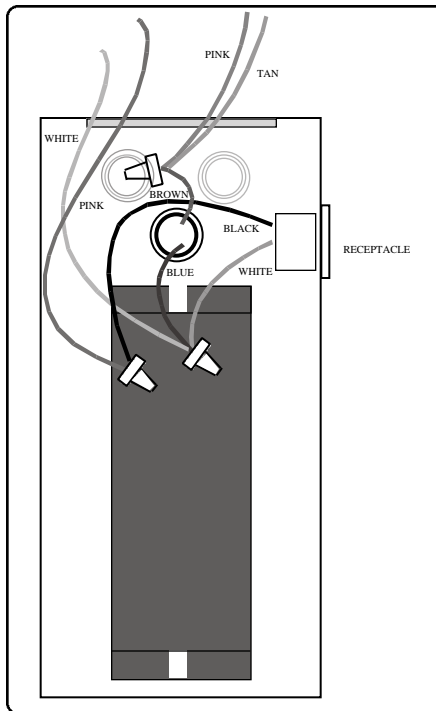

Figure 2  
Ballast Box Before Surge Protector

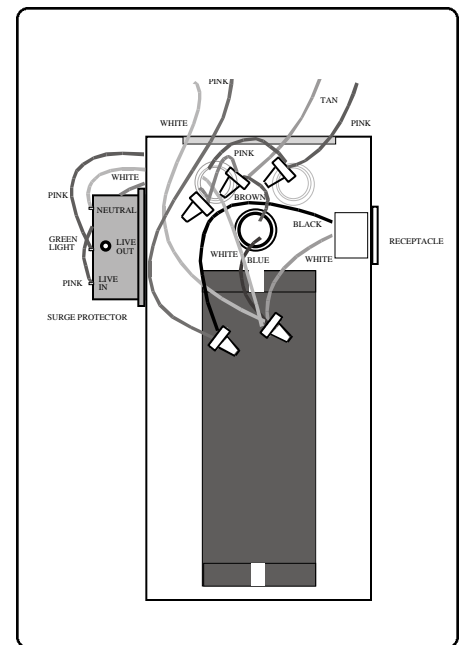

Figure 3  
Ballast Box Before Surge Protector

#### NOTE

Check all wiring to make sure it is correct. Connections should be verified against Figures 3 and 4.

#### STEP 9

- Neatly replace wires into ballast box and replace lid.
- Plug in cabinet. Green light on surge protector should be "off".
- Cabinet now has power. There will be a 3 minute delay before the pump will start.
- Test voltage.
- After start-up delay, cabinet should operate normally.
- Replace louvered grill cover and secure with four phillips-head screws.

# **Notes**

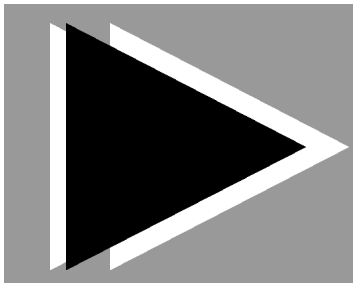

# ***DOOR AND LOCK REPAIR***

In this section you will find instructions on how to replace or repair door assemblies, along with how to field install locks on cabinets.

## INSTALLATION INSTRUCTION

### GLASS INSERT - SLIDE DOOR

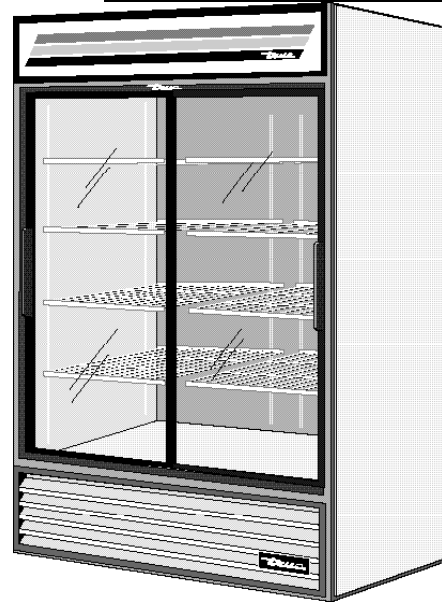
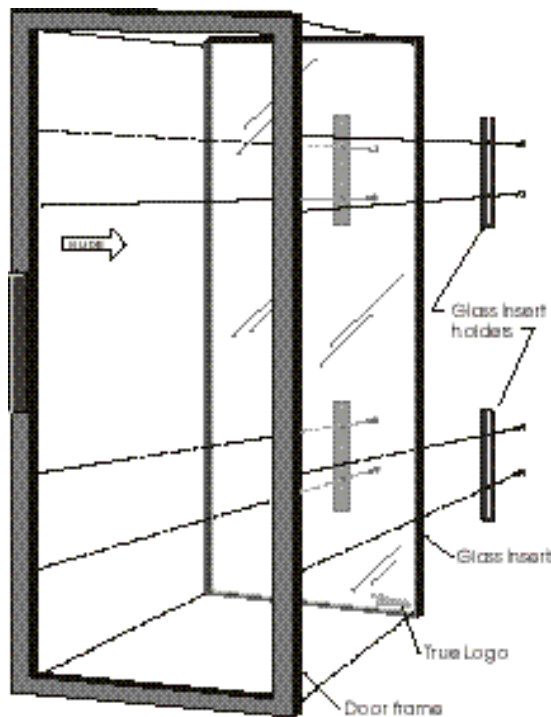

GDM-45

#### REQUIRED TOOLS

- Phillips Head Screwdriver
- 3/8" Wide Double-Sided Tape

#### STEP 1

Slide left door (door positioned on outside track) to the right. Lift door up and pull out at the bottom. Right door (door positioned on inside track) can be removed in the same manner.

#### STEP 2

Remove the nylon cord from the top of the door.

#### STEP 3

Set the door (handle side down) on a flat surface.

#### STEP 4

Remove the screws that secure the four glass insert holders to the door. Remove all four aluminum pieces.

#### STEP 5

Beginning at the corners carefully pry the broken glass loose from the frame. If necessary use heat gun or hair dryer aimed in the space between glass insert and door frame to lessen adhesion of double-sided tape. Carefully dispose of the damaged glass.

#### STEP 6

Remove any excess tape or glass from the lip on the door frame. Replace with new double-sided tape on the 1/2" lip.

#### STEP 7

Remembering to keep the tempered glass to the handle side of the frame place the new glass insert inside the frame and press against the two-way tape. (The etched **TRUE** logo is positioned on the tempered glass side.)

#### STEP 8

Replace the four Aluminum glass insert holders.

#### STEP 9

Reconnect the nylon cord to the top of the door and replace the door as originally removed.



## INSTALLATION INSTRUCTION

### Slide Door Instruction - To improve slide door closing

Check the cooler to see that it is level before searching for a solution. Place a level on the center of the lower channel and on the v-track in several places. The different areas involved with the closing of the door are as follows...

#### Plastic Channel

The plastic channel area: This includes the top, bottom, v-track, and bumpers.

- a. Inspect the top and bottom channels for blockage. Inspect the v-track for dents or movements that may be causing the door to bind. The v-track may be adjusted slightly by bending the "v" with a number 8r vise grips. The v-track can be realigned or replaced. Shims under the door can be adjusted or added to, to improve the seal and speed of closing of the door.

#### Door

The door: This area includes v-roller bracket assembly, stainless insert holder, slot on top of door (where cord is fastened) the foam tape on the door, and the plastic buttons on the inside of the door.

- a. Inspect the v-rollers, clean, realign, and lubricate (the rollers should spin freely) or replace. Be sure the roller bracket screws do not touch the v-track.
- b. Check to make sure door is square. If not loosen stainless insert holders then retighten insert holders. Push on glass insert and break the seal between insert and 2 sided tape. Square the door by

placing shims between frame and glass insert, and then reinstall the insert holders.

- c. Replace the door (with door disconnected) from cord. Slide the door in both directions. Look for binding in the channel area at the top and bottom. Check the stainless insert holder, the 1/4" - 3/8" foam tape, the nylon buttons, and the gasket. Adjust or replace the v-track to ease any binding.

#### Door Weights

The door weight area: This area includes the weight, the nylon cord, the assembly for holding the door open, and the copper guides for the nylon cord.

- a. Remove the door and disconnect the cord. Pull the cord and release it gradually. Does the weight feel like it is binding? Remove the knot in the weight. Remove any excess cord at the knot. The knot should be inside the weight to minimize the friction. Is the weight dropping in the middle of the cover or to the front of the cabinet? The weight dropping in the middle of the cover or to the front of the cabinet? The weight should hang in a vertical position (no angle). Inspect the weight itself and the holes in it. Replace the weight if holes are too far off center and are affecting the travel in the door weight area.

#### Gasket

The gasket area: This area includes the 3" plastic, 1 3/8 plastic, the gasket and the 11/16" gasket insert holder. Inspect the door to make sure it is seating against gasket.

#### TO ELIMINATE GAPS ON SLIDE DOOR COOLERS

1. Adjust leg levelers to eliminate gap.
2. Place shims between the roller brackets and the door.
3. Remove gasket and shim needed locations.
4. Shim v-track.



## INSTALLATION INSTRUCTION

### Wiper Gasket Installation

#### REQUIRED TOOLS

- Drill
- 1/8" Drill Bit
- Pop Rivet (2 Per Door)



Top View of Wiper Gasket.



The short side of the gasket is what seals between the doors.

**SHOULD YOU HAVE ANY ADDITIONAL QUESTIONS, PLEASE FEEL FREE TO CONTACT THE TECHNICAL SERVICE DEPARTMENT.**

#### STEP 1

Before removing the doors from the cabinet, mark each door in the area where the wiper gasket will be applied at the point of the center leg on the top and bottom door channels. See #1. Use the reference marks for the vertical positioning of the wiper gasket.

#### STEP 2

Remove the doors by lifting the left door up and swing the bottom out. Remove the door cord attached to the top of the door. Repeat these steps for right door. Place the left door with the handle down and place the right door with the handle up.

#### STEP 3

Drill out the rivets that secure the wiper Gasket and remove all residues from the door surface where the wiper gasket will be applied.

#### STEP 4

Peel off the adhesive tape on the back side of the gasket and apply one wiper gasket to the back of the outside (left) door. Position the wiper gasket at least 3/8" in from the door frame on the inside (right) door.

#### STEP 5

Drill one 1/8" hole through the top and Bottom of the wiper gasket holder and in to the door frame about 1/2" from the top of the blade and replace the pop rivets.

#### STEP 6

On coolers with 3 doors, locate and adjust the blade to the back frame in the center door as needed making sure that the right door will operate freely and secure it with pop rivets. Make sure that the wiper gasket does not drag against the door tracks.

# INSTALLATION INSTRUCTION

## Removal and Installation of GDM & Old Style T-Series - Swing Door

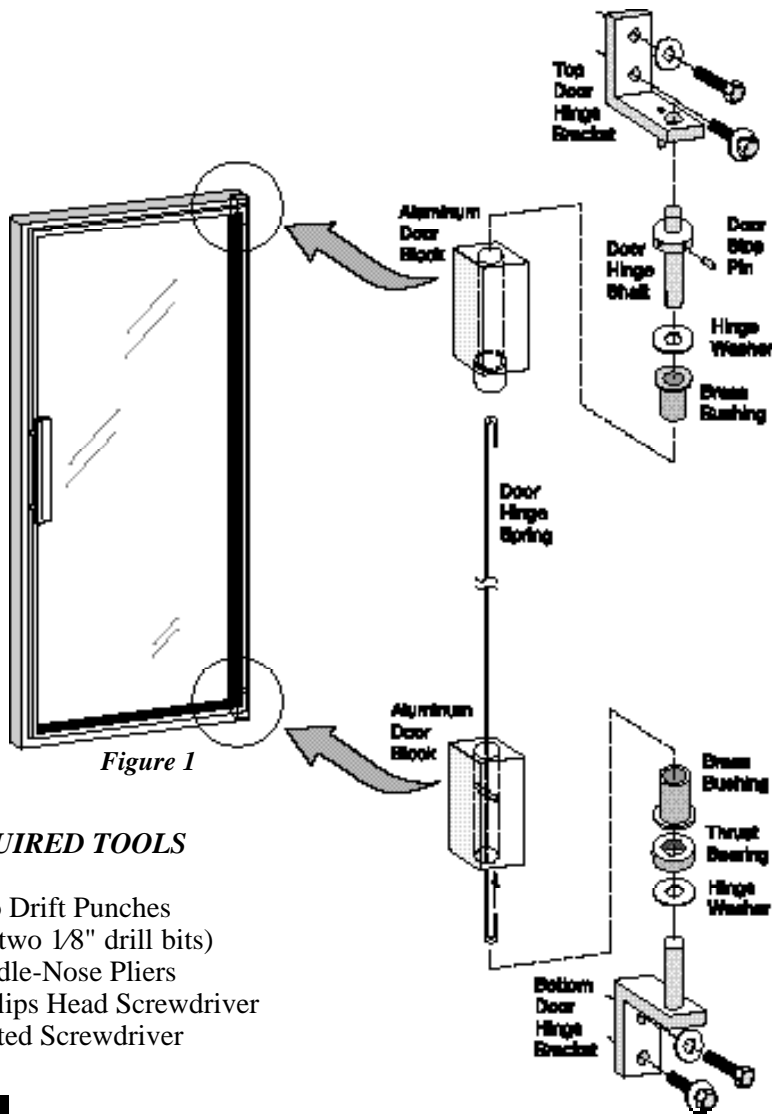

Figure 1

### REQUIRED TOOLS

- Two Drift Punches (or two 1/8" drill bits)
- Needle-Nose Pliers
- Phillips Head Screwdriver
- Slotted Screwdriver

### NOTE:

*For greater safety and ease of installation it is recommended that two people assist in replacement procedure.*

### STEP 1

Turn the cooler off.

### STEP 2

Remove the four mounting screws from louvered grill and remove grill.

### STEP 3

For models with the integrated door light feature, unplug light from ballast box.

### IMPORTANT:

*Freezer doors have heater wires which must be unplugged before doors can be removed.*

### STEP 4

Locate the top hinge assembly.

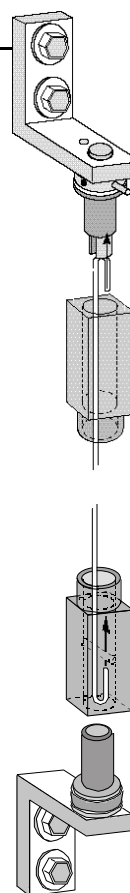

### STEP 5

Remove Door Stop Pin by placing a drift punch or 1/8" drill bit into the stop pin hole two holes to the left (for right side door) of the stop pin position. With drill bit firmly anchored in position, apply back pressure to the left and remove the stop pin with a needle-nosed pliers. While firmly holding the drill bit with your left hand begin rotating the hinge shaft to the right relieving spring tension. Insert second drift punch or drill bit into hole to the left and repeat process until all spring tension is relieved.

In some instances it is necessary to relieve spring pressure one hole position at a time until spring pressure is relieved.

### NOTE

*Operation is reversed for left side door.*

## INSTALLATION INSTRUCTION

### REMOVAL AND INSTALLATION OF A GDM-SWING DOOR ...Continued

**NOTE:**

*If cabinet is equipped with integrated door light be sure to unplug from ballast box.*

**NOTE:**

*Freezer doors have heater wires which must be unplugged before doors can be removed.*

#### STEP 6

In a squatted position, rest the bottom of the open door on your left knee (for right side door) as you face the outside of the door. Create an upward pressure and remove the two 3/8" bolts from the bottom hinge assembly. Remove the bottom hinge assembly. (Figure 2)

#### Glass Door Replacement Instruction

#### STEP 7

Carefully place door on a flat surface.



Figure 2

#### REQUIRED TOOLS

- Phillips Head Screwdriver
- Two Drift Punches  
(or two 1/8" drill bits)

**NOTE:**

*It may be necessary to verify stop pin location and door block material for some models. Or call 800-325-6152 for assistance*

#### STEP 1

Beginning with the top hinge assembly of the replacement door place the hinge washer over the hinge shaft and slide into top aluminum door block. (figure 1)

**NOTE:**

*The slot at the base of the hinge shaft must seat over the head of the door hinge spring.*

#### STEP 2

Insert the bottom hinge assembly (hinge bracket, hinge washer, thrust bearing) into aluminum door block and brass bushing inside bottom frame. (figure 1)

#### STEP 3

While holding bottom hinge in place lift door and slide top door hinge together. Maintain vertical pressure by resting door bottom on your knee while squatting, or have someone assist in order to re-attach lower hinge to cabinet. Fasten hinge with 3/8" bolts and washers.

#### STEP 4

Replace the louvered grill on the cooler with the four screws

#### STEP 5

Adjust the spring by rotating the door hinge shaft to the left (using two drift punches or 1/8" drill bits) hole by hole to the desired tension (approximately one-half turn). Replace the stop pin in the door hinge shaft.

**NOTE:**

*If cabinet is equipped with integrated door light, be sure to plug into ballast box.*

**NOTE:**

*Freezer doors have heater wires which must be plugged in before operation.*

**To adjust door hang -**  
*Loosen bolts from bottom hinge assembly and lightly tap with plastic or rubber hammer.*  
*When door hangs true, tighten bolts.*

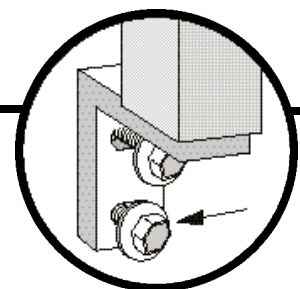

# INSTALLATION INSTRUCTION

## TORSION SPRING REPLACEMENT New Style T-Series & GDM Radius Front- SWING DOOR

**NOTE:**

*If the torsion spring is broken, there is no need for steps 1-4.*

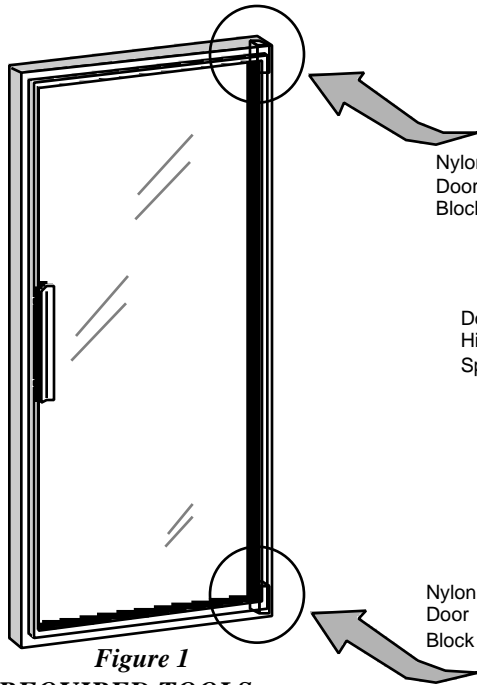

Figure 1

**REQUIRED TOOLS**

- Drift Punch (or 1/8" drill bit)
- Needle-Nose Pliers
- Phillips-Head Screwdriver
- Slot-Head Screwdriver
- Wrench (3/8")

**STEP 1**

Turn the cooler off.

**STEP 2**

Locate the top hinge assembly.

**STEP 3**

If spring remains taut, relieve tension by placing a drift punch or 1/8" drill bit into the stop pin hole, two holes to the left (for right side door) of the stop pin position.

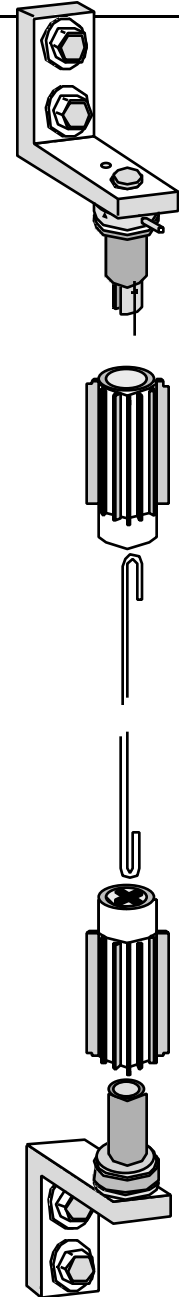
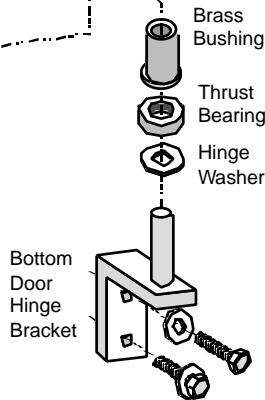
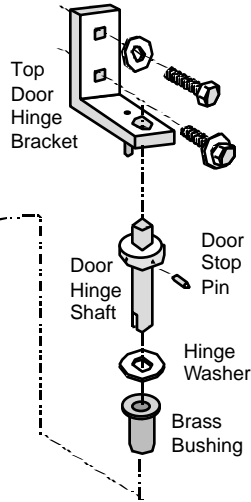

**STEP 4**

process until all spring tension is relieved.

In some instances it is necessary to relieve spring pressure one hole position at a time until spring pressure is relieved.

**NOTE:**

*Operation is reversed for left side door.*

## INSTALLATION INSTRUCTION

### TORSION SPRING REPLACEMENT - SWING DOOR...Continued

#### STEP 5

Remove all 4 anchor screws from louvered grill and remove grill.

**NOTE:**

*If cabinet is equipped with integrated door light be sure to unplug from ballast box.*

**NOTE:**

*Freezer doors have heater wires which must be unplugged before doors can be removed.*

#### STEP 6

In a squatted position rest the bottom of the open door on your left knee (for right side door) as you face the outside of the door. Create an upward pressure and remove the two 3/8" bolts from the bottom hinge assembly. Remove the bottom hinge assembly. (figure 2)

#### STEP 7

Remove the door and carefully place door on a flat surface.



#### STEP 8

Remove upper and lower brass bushing from from the top and bottom of door with a slotted screwdriver or needle-nosed pliers if, required.

**NOTE:**

*It may be necessary to verify stop pin location and door block material for some models. Or call 800-325-6152.*

#### STEP 9

Using a needle-nosed pliers, remove the broken torsion spring from the bottom of the door.

#### STEP 10

Insert the new spring from the top of the door ensuring that the end hooks into the cross in the bottom door block. The gap in the hook should be wide enough to snugly fit.

#### STEP 11

Assemble top hinge. Place the hinge washer over the door hinge shaft, slide into brass bushing and fit into aluminum door block. (figure 1)

**NOTE:**

*The slot at the base of the hinge shaft must seat over the head of the door hinge spring.*

#### STEP 12

Assemble bottom hinge. Place the hinge washer over the bottom hinge bracket, replace the thrust bearing over the washer, slide this assembly into the brass bushing and fit into aluminum door bracket.

#### STEP 13

While holding bottom hinge in place lift door and slide top door hinge together. Maintain vertical pressure by resting door bottom on your knee while squatting, or have someone assist in order to re-attach lower hinge to cabinet. Fasten hinge with 3/8" bolts and washers.

#### STEP 14

Adjust the spring tension by turning counter-clockwise (right door) to the desired tension (approx. 1/2 turn). Again use a 1/8" drill or drift punch to adjust and replace stop pin.

**NOTE:**

*If cabinet is equipped with integrated door light be sure to plug into ballast box.*

**NOTE:**

*Freezer doors have heater wires which must be plugged in before operation.*

#### STEP 15

Replace louvered grill and secure with four screws.

#### To adjust door hang -

*Loosen bolts from bottom hinge assembly and lightly tap with plastic or rubber hammer.*

*When door hangs true with cabinet, tighten bolts.*

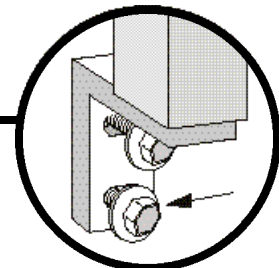

# INSTALLATION INSTRUCTION

## IDL Lamp Replacement

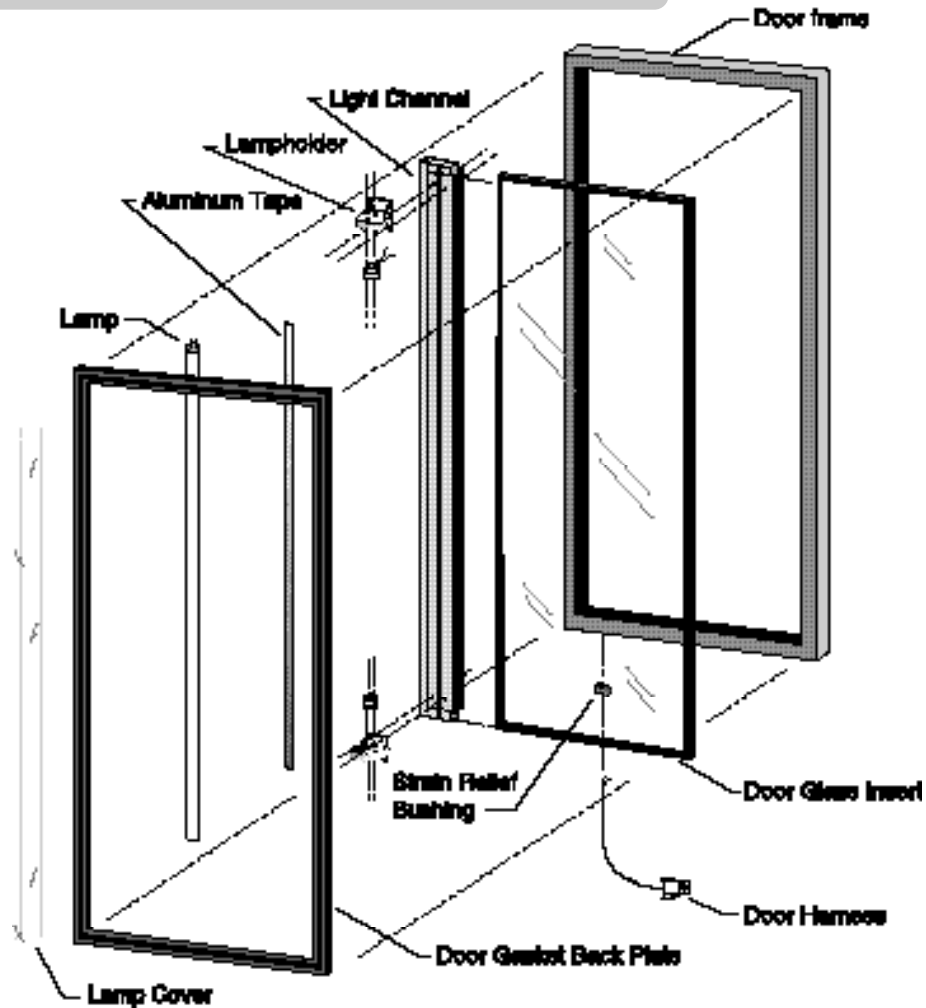

Figure 1

**STEP 1**

Unplug the cooler.

**STEP 2**

Remove lamp cover by squeezing it in the center, twist and pull outward.

**STEP 3**

The lamp can then be removed by pushing it up and then out. This will release the lamp from the lower lamp holder. At this point the lamp can be totally removed.

**STEP 4**

Install the new lamp by placing the lamp terminals in the upper lamp holder first.

**STEP 5**

Push up on the bulb to recess the upper holder.

**STEP 6**

With the upward pressure applied, line up the terminal on the lower end of the bulb with the lamp holder. Once aligned the lamp will snap into place.

**STEP 7**

Pull on bulb to make sure it is seated properly.

**STEP 8**

Replace lamp cover by squeezing and snapping into retainer on lamp assembly.

**STEP 9**

Plug in the cabinet.

**STEP 10**

If lamp does not illuminate another problem may exist.



# INSTALLATION INSTRUCTION

## GLASS INSERT - SWING DOOR

### Glass Door Refrigerator Replacement Instruction

(See opposite page for freezer instruction)

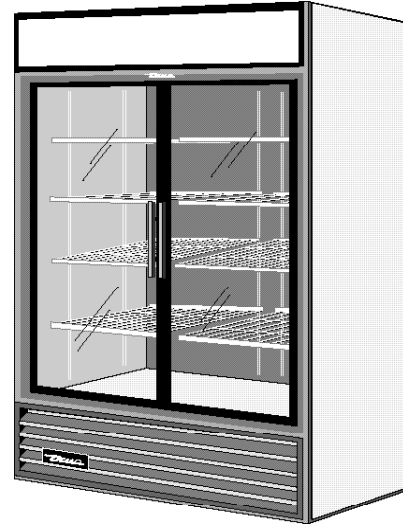
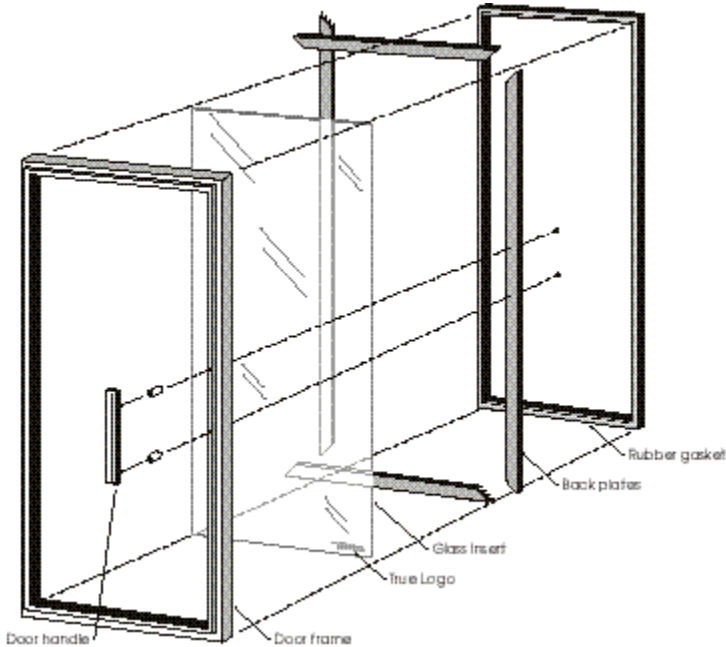

**GDM-49**

#### REQUIRED TOOLS

- Phillips Head Screwdriver
- 3/8" Wide Double-Sided Tape

**NOTE:**  
*For greater safety and ease of installation it is recommended that two persons assist in replacement procedure.*

**IT IS NOT NECESSARY TO REMOVE THE DOOR FROM THE CABINET**

#### STEP 1

Turn the cooler off.

#### STEP 2

Remove the rubber gasket from the perimeter of the interior side of the door.

Remove the door handle (two screws).

#### STEP 4

Remove the screws that secure the four back plate pieces to the door. Remove all four back plates.

#### STEP 5

Beginning at a corner carefully pry the broken glass loose from the frame. If necessary use heat gun or hair dryer aimed in the space between glass insert and door frame to lessen resistance of double-sided tape. Carefully dispose of the damaged glass.

#### STEP 6

Remove any excess tape or glass from the lip on the door frame. Replace with new double-sided tape on the 1/2" lip.

To support glass insert use one-sided tape to secure two plastic shims (3/32" x 7/8" x 2-1/2") on opposite ends of bottom door frame a few inches from the corners.

#### STEP 7

#### STEP 8

Remembering to keep the tempered glass to the handle side of the frame place the new glass insert inside the frame and press against the two-way tape. (The etched TRUE logo is positioned on bottom corner of the tempered glass side.)

#### STEP 9

Square up door by adding shims between glass insert and the handle side of the door frame.

# INSTALLATION INSTRUCTION

## GLASS INSERT - SWING DOOR ...CONTINUED

### Freezer - Glass Door Replacement Instruction

#### STEP 10

Place double sided tape on all edges of glass insert to create a seal with the back plate.

#### STEP 11

Replace bottom back plate then top and side plates. Tighten all screws.

#### STEP 12

Replace the handle.

#### STEP 13

Snap the gasket back into the back plate.

#### REQUIRED TOOLS

- Phillips Head Screwdriver
- 3/8" Wide Double-Sided Tape
- (2) Self Stripping Connectors

**NOTE:**  
*For greater safety and ease of installation it is recommended that two persons assist in replacement procedure.*

**IT IS NOT NECESSARY TO REMOVE THE DOOR FROM THE CABINET**

*Follow steps 1 - 4 of refrigerator glass insert installation*

#### STEP 5

Freezer doors have heater wires running through the door frame and around the rear side of the glass insert which junction at the lower inside corner and plug into the compressor area. The glass insert must be carefully pried loose starting from the top corner and working down to gently free the glass insert

without damaging the heating element. If necessary use heat gun or hair dryer aimed in the space between glass insert and door frame to lessen resistance of double-sided tape. It is recommended that one person support the damaged glass insert while the other releases the wires from the two self stripping connectors.

Carefully dispose of the damaged glass.

Follow steps 6 - 7 of refrigerator glass insert installation.

#### STEP 8

Rejoin heater wires using self stripping connectors (black to black & white to white) as shown in figure 2.

- Place self stripping connectors on heater wire leads as shown in diagram a.
- Insert leads from bottom of replacement glass into appropriate self stripping connectors (black to black & white to white) as shown in diagram b.

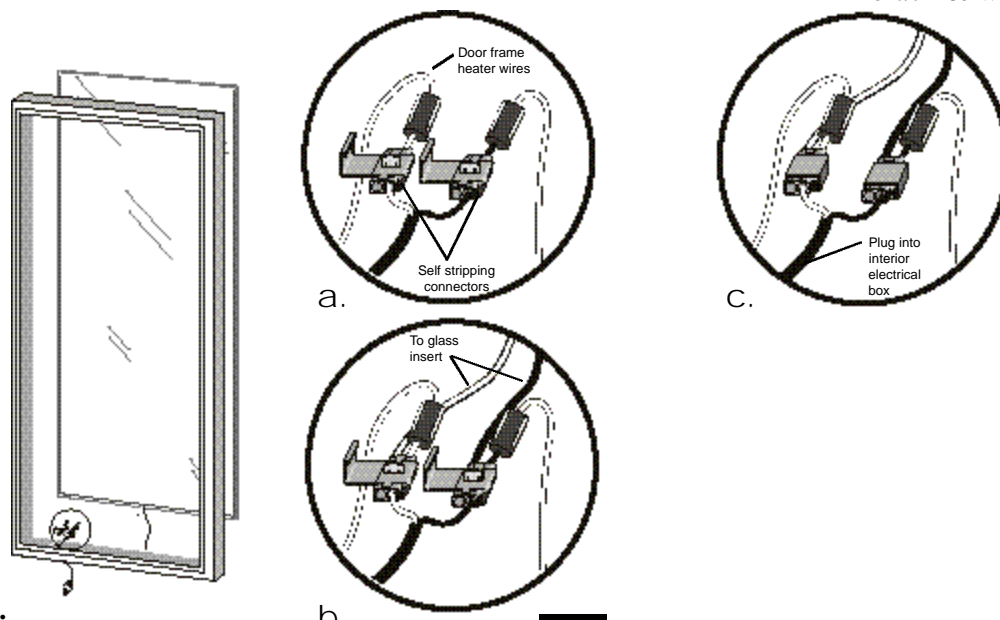

l self stripping connector in diagram c.

**8 - 13 of refrigerator insert installation**

Figure 2.



## INSTALLATION INSTRUCTIONS

### Glass Insert Gas Release (High Altitude Installation)

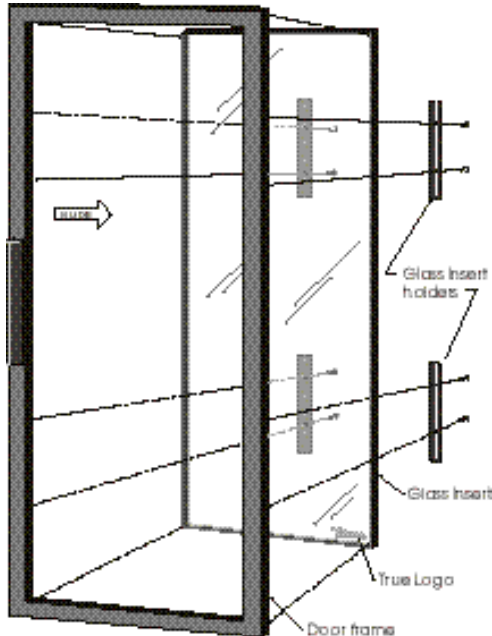

### Top View of Glass Insert (Step 6-7)

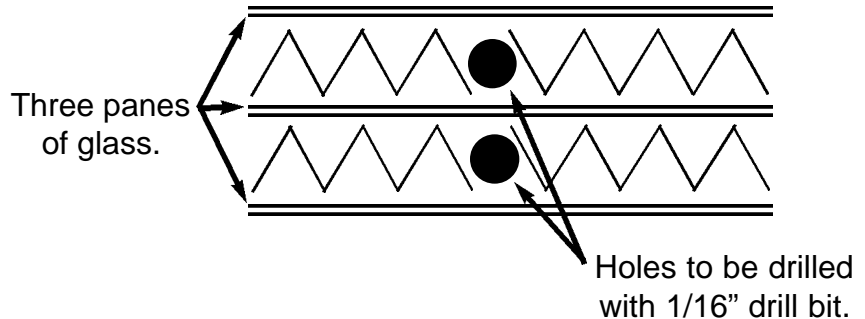

#### Required tools:

- Phillips head screwdriver
- 3/8" Wide double sided tape
- 1/16" Drill Bit
- Drill
- Silicone

#### STEP 1

Slide left door (door positioned on outside track) to the right. Lift door up and pull out at the bottom. Right door (door positioned on inside track) can be removed in the same manner.

#### STEP 2

Remove the nylon cord from the top of the door.

#### STEP 3

Set the door (handle side down) on a flat surface.

#### STEP 4

Remove the screws that secure the four glass insert holders to the door. Remove all four aluminum pieces.

#### STEP 5

Beginning at the corners carefully pry the broken glass loose from the frame. If necessary use heat gun or hair dryer aimed in the space between glass insert and door frame to lessen resistance of double-sided tape.

#### STEP 6

Carefully use the drill with a 1/16" drill bit to drill through the spaces between the glass.

#### STEP 7

After gas is released from in between both panes use the silicone to reseal drill holes.

#### STEP 8

Remove any excess tape or glass from the lip on the door frame. Replace with new double-sided tape on the 1/2" lip.

#### STEP 9

Remembering to keep the tempered glass to the handle side of the frame place the new glass insert inside the frame and press against the two-way tape. (The etched TRUE logo is positioned on the tempered glass side.)

#### STEP 10

Replace the four Aluminum glass insert holders.

#### STEP 11

Reconnect the nylon cord to the top of the door and replace the door as originally removed.

## GDM & T SERIES IDL GLASS INSERT REPLACEMENT



### **Warning:**

*The Edges on the glass insert are very sharp. To avoid personal injury, use adequate protection for your eyes and hands when working or handling this or any other glass component.*

### **Required tools:**

- Phillips head screwdriver
- 3/8" Wide double sided tape
- Side cutters (if working with freezers)
- Butt connectors (if working with freezers)
- Crimping tool (if working with freezers)

### STEP 1

Disconnect power to the cabinet.

### STEP 2

Disconnect IDL plug from cooler.

### STEP 3

Loosen up the tension from torsion spring and remove door. *Refer to Removal and Installation of GDM and T-Series Swing Door Instructions on page 46-47.*

### STEP 4

Remove doors handle and place door on a flat surface.

### STEP 5

Remove door gasket and back plates from the top, bottom and handle side.

### STEP 6

Beginning at the upper corner in the handle side, carefully pry the broken glass loose. If necessary, use a heat gun or hair dryer to loosen up the insert from double sided tape.

### **Note:**

***Do not forget to disconnect the glass insert heater wires before pulling it out and reconnect them before sliding the new glass insert in.***

### STEP 7

Remove any excess tape and glass from the lip on the door's frame and replace with new double sided tape.

### STEP 8

Install the new glass insert by pushing it into the light channel first and then work out-wards toward the handle side.

### **NOTE:**

***Make sure the TRUE logo on the insert, is located outside at the bottom of the frame.***

### STEP 9

Install gasket back plates and gasket.

### STEP 10

Mount door and tighten torsion spring. *Refer to Removal and Installation of GDM and T-Series Swing Door Instructions on page 46-47.*

# ▶ **REPLACEMENT OF DOOR FRAME HEATER ON IDL FREEZER DOORS** —

**Tools Required:**

- Phillips Head Screwdriver
- 3/8" Socket Set
- Awl
- Wire Strippers-Crimper
- Needle Nose Pliers

**Note:**

***For greater safety and ease of installation, it is recommended that two persons assist in the replacement procedure.***

**Note:**

***It may not be necessary to remove the door from the cabinet if two persons are assisting in the replacement procedure.***

\_\_\_\_\_ **STEP 1** \_\_\_\_\_

Disconnect electrical power to cabinet.

\_\_\_\_\_ **STEP 2** \_\_\_\_\_

Remove door from cabinet and lay on a flat surface. *Refer to Removal and Installation of GDM and T-Series Swing Door Instructions on page 46-47.*

\_\_\_\_\_ **STEP 3** \_\_\_\_\_

Remove door gasket from the perimeter of the interior side of the door.

\_\_\_\_\_ **STEP 4** \_\_\_\_\_

Remove door handle (2 screws).

\_\_\_\_\_ **STEP 5** \_\_\_\_\_

Remove the screws that secure the four back plates to the door.

\_\_\_\_\_ **STEP 6** \_\_\_\_\_

With your Awl, pry out plastic shims wedged between glass insert and door frame.

\_\_\_\_\_ **STEP 7** \_\_\_\_\_

Before removing glass insert, disconnect the electrical wiring to door frame heater and heater inside glass insert. Note: Wiring harness connection for your info: 2-whites go to 2-whites on lower lamp socket. 2-blacks go to 2-blacks on upper lamp socket. 1 red is 115v lead to both frame and insert heaters. 1 blue is neutral to both frame and insert heaters.

\_\_\_\_\_ **STEP 8** \_\_\_\_\_

Remove glass insert by pushing on insert in upper corner of the handle side. If necessary, use a heat gun or hair dryer aimed in the space between glass insert and door frame to lessen resistance of double stick tape.

**Note:**

***For safety, gloves and eye protection should always be worn when handling glass.***

\_\_\_\_\_ **STEP 9** \_\_\_\_\_

Once glass has been removed, this

will expose the heater wires inside door frame. Remove old heater and replace with new heater cable.

\_\_\_\_\_ **STEP 10** \_\_\_\_\_

Remove any old tape from the lip on the door frame. Replace with new double-sided tape on the 1/2" lip.

\_\_\_\_\_ **STEP 11** \_\_\_\_\_

Re-install glass insert by first installing two of the plastic shims to opposite ends of bottom door frame a few inches from the corners. Remember to keep the tempered glass to the handle side of the frame and press against the two-way tape.

**Note:**

***The etched TRUE logo is positioned on bottom corner of the tempered glass side.***

\_\_\_\_\_ **STEP 12** \_\_\_\_\_

Square glass insert to door frame by adding shims to the handle side.

\_\_\_\_\_ **STEP 13** \_\_\_\_\_

Replace backplates, door handle and gasket.

\_\_\_\_\_ **STEP 14** \_\_\_\_\_

Re-install door on freezer (if removed). *Refer to Removal and Installation of GDM and T-Series Swing Door Instructions on page 58-61.*

# INSTALLATION INSTRUCTION

## IDL Door-Wire Harness Replacement



### STEP 1

Unplug the cooler and door harness and remove louver grill. Remove "P" clip.

### STEP 2

Take the door off the cooler and place on a flat stable surface. Refer to *Removal and Installation of GDM and T-Series Swing Door Instructions* on page 58-61.

### STEP 3

Remove door gasket.

### STEP 4

Remove back plastic. This will require a phillips screwdriver.

### STEP 5

Remove the glass insert. This can be done by placing a putty knife between frame and the insert. Then pry the insert up and out of the frame. The insert will stick due to double sided tape that is used to hold.

### STEP 6

Remove the strain relief bushing on the underside of the door frame.

### STEP 7

Pull light channel to expose lamp holder and door harness connection.

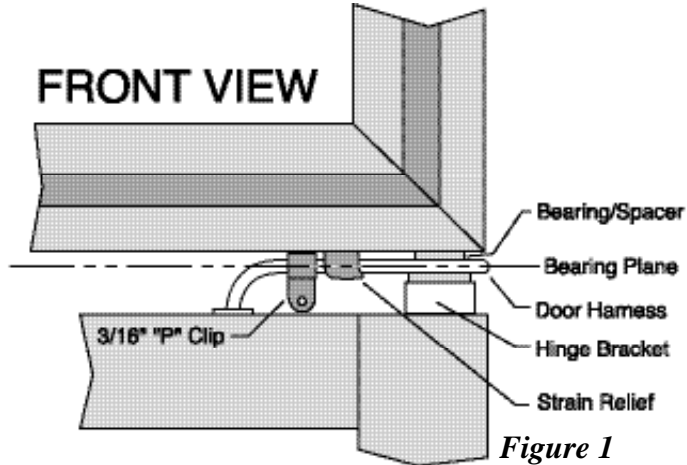

Figure 1

- \* With door closed, all slack in the harness should be pulled out before fastening the "P" clip.
- \* "P" clip should hold harness in place with the hinge bearing.

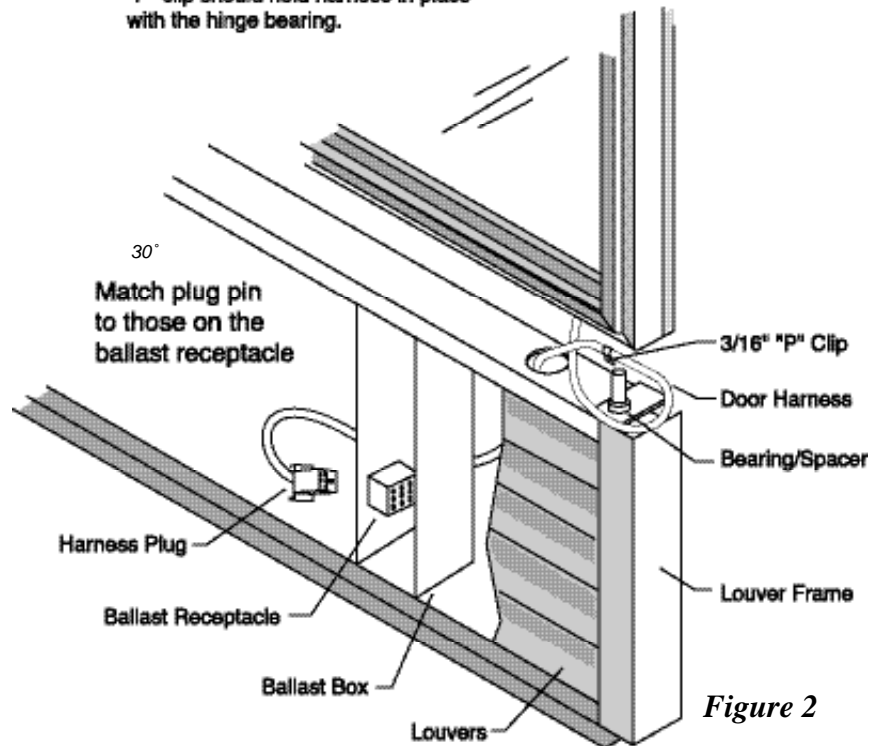

Figure 2

### STEP 8

Cut the lamp holder wires directly above the lamp connectors.

### STEP 9

Remove the door harness.

# ▶ INSTALLATION INSTRUCTION

## IDL Harness Replacement ...Continued

### STEP 10

Check the physical dimension of the new cord. If the new cord is thicker it is necessary to enlarge the hole in the door frame. Enlarge the hole using a 5/8" drill bit.

### STEP 11

Place strain relief around the new door harness.

### STEP 12

Route door harness through frame hole to allow connection to lamp holder wires.

### STEP 13

Strip lamp holder wires and door harness wires.

### STEP 14

Match wires (see wiring pairing) and crimp on end connectors to each set.

### STEP 15

Put the light channel back in its original position. Be sure wires are not pinched within the frame. Remove excess slack by pulling on door harness.

### STEP 16

Place the strain relief back into the door frame.

### STEP 17

Replace the glass insert. Make sure double sided tape is not bunched or lying outside of the door frame. The insert should slide into the light channel first, this may require force. Once in the channel then lay within the frame opening.

### STEP 18

Replace the back plastic. Match up existing screw holes and use existing screws to fasten.

### STEP 19

Replace the gasket and hang the door.

#### NOTE:

***A test should be run before re-hanging the door. Simply support the door and plug it into the ballast receptacle. Plug the cooler in and see if the door light comes on.***

### STEP 20

***See figures 1 & 2.***

Route the door harness per figure 2.

### STEP 21

Place "P" clip as shown. Be sure all the slack in the door harness is removed before tightening the clip. Also, be sure the clip is placed in plane with the hinge bearing.

#### NOTE:

***If larger cord is being used you will also have to replace the p-clip. This will be included in the replacement kit.***

### STEP 22

Plug the harness receptacle into the ballast receptacle and reinstall the louver grill.

### STEP 23

Plug in the cabinet and test.

### WIRE PAIRING

#### Door harness to lamp holder

The lamp holder combination will have two black wires and two white wires. The door harness will have either two black and two white wires or one green, one red, one black and one white wire. Below are the wire combinations for each.

#### Multi colored door harness to lamp holder

Green wire	to	Black wire
Red wire	to	Black wire
White Wire	to	White Wire
Black Wire	to	White Wire

#### White/Black door harness to lamp holder

White Wire	to	White Wire
Black Wire	to	Black Wire



## **INSTALLATION INSTRUCTION**

### **SHIMMING THE GLASS INSERT**

---

Under normal circumstances your True Merchandiser won't require any type of adjustments, except for the ones already outline in your installation instructions. When install properly you will have a perfectly aligned piece of equipment. There will be however some occasions in which it will be necessary to go a little deeper in order to accomplish a perfect alignment. One of the most common problems at installation is the door(s) sagging or unaligned, to correct this condition here are the recommended procedures:

1. Make sure that there is no damage to the door(s) or the cabinet.
2. Try to level the door(s), by adjusting the leveling legs. Perform this procedure by adding castor shims if the unit is on castors.
3. Try to align the door(s) by adjusting the bottom hinge left or right on the swing type door(s).

Usually by performing these procedures the alignment of the door(s) is accomplished. If after performing these procedures the problem persists, it is recommended to adjust the glass insert to square door by shimming it. To shim the glass insert the recommended procedures are as follows:

**WARNING: SAFETY GLASSES SHOULD BE USED WHEN HANDLING OR WORKING WITH THIS OR ANY OTHER GLASS.**

- a. Remove the gasket from the gasket base.
- b. Remove the screws holding the gasket base around the door and remove the gasket base.
- c. With a putty knife loosen up the glass insert around the door frame.  
It might be necessary to use a heat gun.
- d. With a two by four or a similar device, proceed to lift the door frame by prying from the bottom outer corner. See Photos 1 and 2.
- e. Shim the glass insert wherever there is a space between the frame and the insert.  
See photo 3 and 4.
- f. Press the insert against the door frame and re-install the gasket base and the gasket.

**INSTALLATION INSTRUCTION**  
**SHIMMING THE GLASS INSERT CONTINUED**



## INSTALLATION INSTRUCTION

### Lock Installation - GDM - model 23/26 single swing door

#### REQUIRED TOOLS

- tape measure
- 1/4" drill
- 2" saw drill hole saw
- 3/4" saw drill hole saw
- straightedge
- tin snips
- Phillips screwdriver
- file
- drill bit for screws on lock cup

#### STEP 1

Drill 1/4" pilot hole 37" from the top of the cooler and 1 9/16" down from end panel edge. Pierce through wall thickness and then rock slightly to create a vertical slot approximately 1/2".

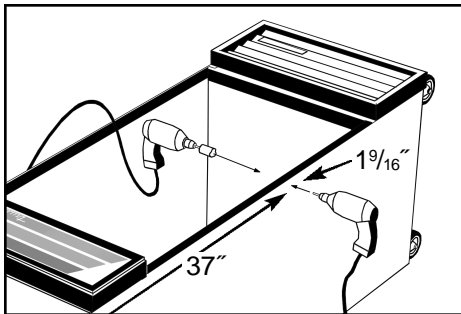

#### STEP 2

Using a 2" hole saw, insert drill into existing hole and align top of bit with the cooler's black tank plastic. Drill far enough to pierce the interior skin (stop at the insulation).

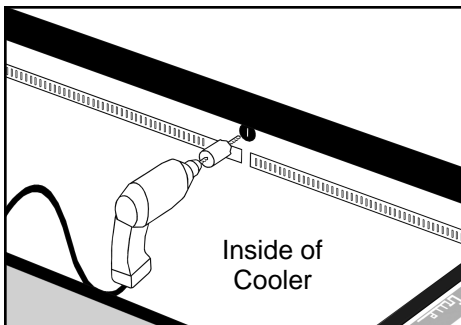

#### STEP 3

Insert 3/4" hole saw into original, exterior pilot hole, and drill through

insulation. Remove insulation from created hole and smooth burs with a file.

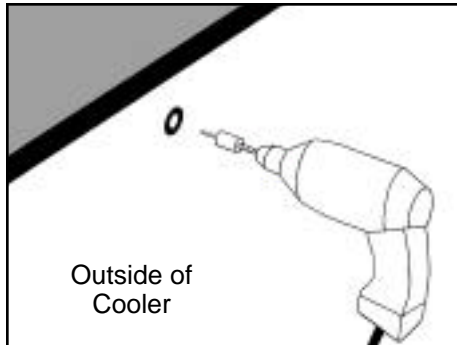

#### STEP 4

Using straightedge, pencil mark a straight line, parallel to the lock cup knockout opening. With tin snips, trim off top of lock cup.

#### STEP 5

Insert lock cup into drilled opening (interior wall), while inserting lock

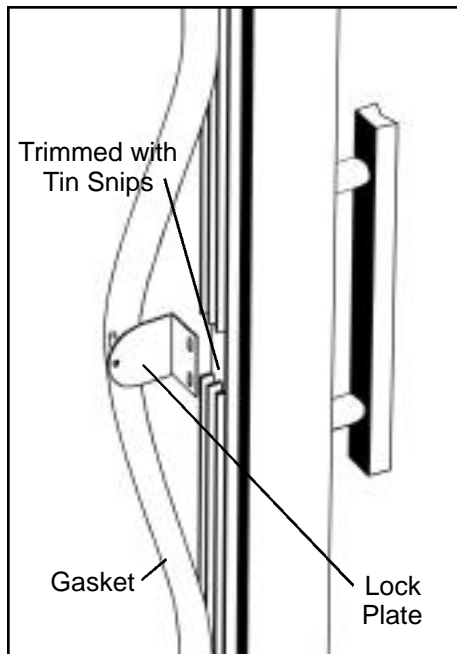

assembly from the exterior wall. Fasten assembly by attaching hex nut. Anchor lock cup with three self-tapping screws.

#### STEP 6

Install latch and secure with phillips washer head screw.

#### STEP 7

Pull gasket away from door trim. Using masking tape as a center point. Score interior door trim using the lock

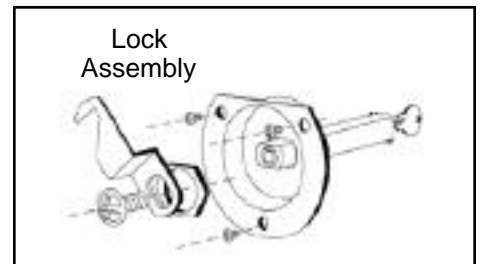

to measure top and bottom width. With tin snips, cutaway door trim in order to accommodate lock plate.

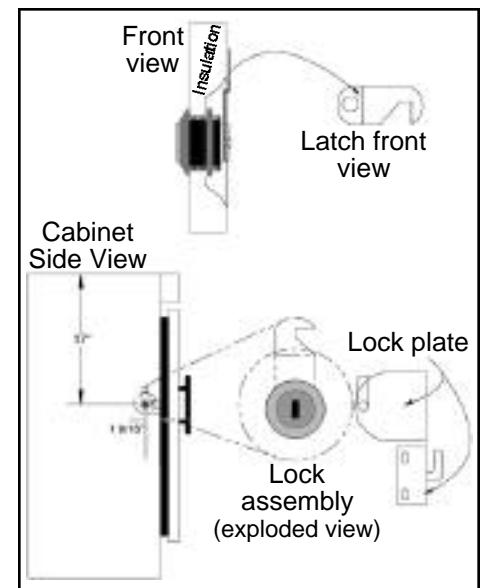

#### Note:

**Other single swing door cabinets please consult True Manufacturing Technical Service at 800-325-6152.**



# INSTALLATION INSTRUCTION

## BARREL LOCK INSTALLATION (GDM slide door models)

### REQUIRED TOOLS

- Drowel tool or sharp knife
- 3/4" hole saw
- Pop rivet tool
- 7/8" deep well socket
- Tape measure
- Phillips screw driver
- Slot screw driver
- #32 drill bit

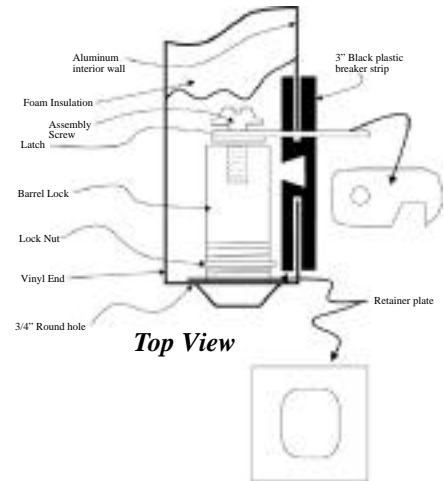
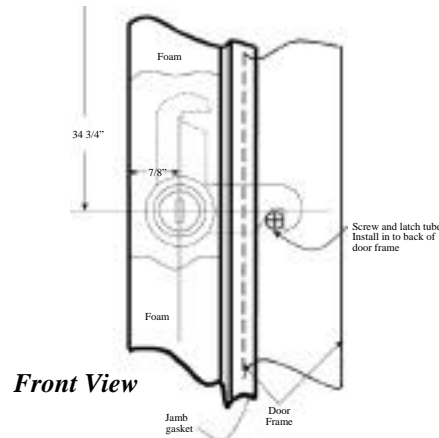

### INSTALLATION

#### STEP 1

Use tape measure and mark a center line at 34 3/4" down from the top of the cabinet on the left end. Mark second center line 7/8" from outside edge of cabinet. This should locate the hole in the end of the cabinet.

#### STEP 2

Use 3/4" hole saw and drill hole on center mark.

#### STEP 3

Remove door jamb gasket from left door jam.

#### STEP 4

Draw center line on black plastic fill in. Align fill in center line with cabinet center line and mark a line along top and bottom to fill in.

#### STEP 5

Using drowel tool or sharp knife, cut out black plastic breaker on marked lines. Remove this section of breaker completely. Some of the aluminum wall will need to be removed to create a large enough compartment to work in.

#### STEP 6

Once the breaker is removed, now the foam can be dug out to form the lock box. Only enough foam should be removed to install lock.

#### STEP 7

Install lock assembly through 3/4" hole. Place retainer plate and lock nut end, tighten with 7/8" socket: Install tumbler and latch assembly and tighten screw.

#### STEP 8

Install black plastic fill in plate working lock to make sure latch will move through the slot. When components operate properly, fasten fill in with black pop rivets.

#### REMINDER

**Remember to install left door gasket**

#### STEP 9

With left door installed, mark rear of door where the notch in the latch meet the door frame. Drill a #32 hole on the mark. Install screw and latch tube assembly into drilled hole. Latch should drop onto tube assembly and lock left door.

#### STEP 10

Install lock bar assembly to rear edge of right door. Install so the bar is 2" from the top of the door in the storage position (use #32 drill bit).

#### STEP 11

Lower bar into locking position. It should be positioned against 3" breaker strip. Install third SS clip so locking bar will fall into it as a pocket. This will hold bar in the locking position (use #32 drill bit).

**SLIDE BARREL LOCK (TOP VIEW)**

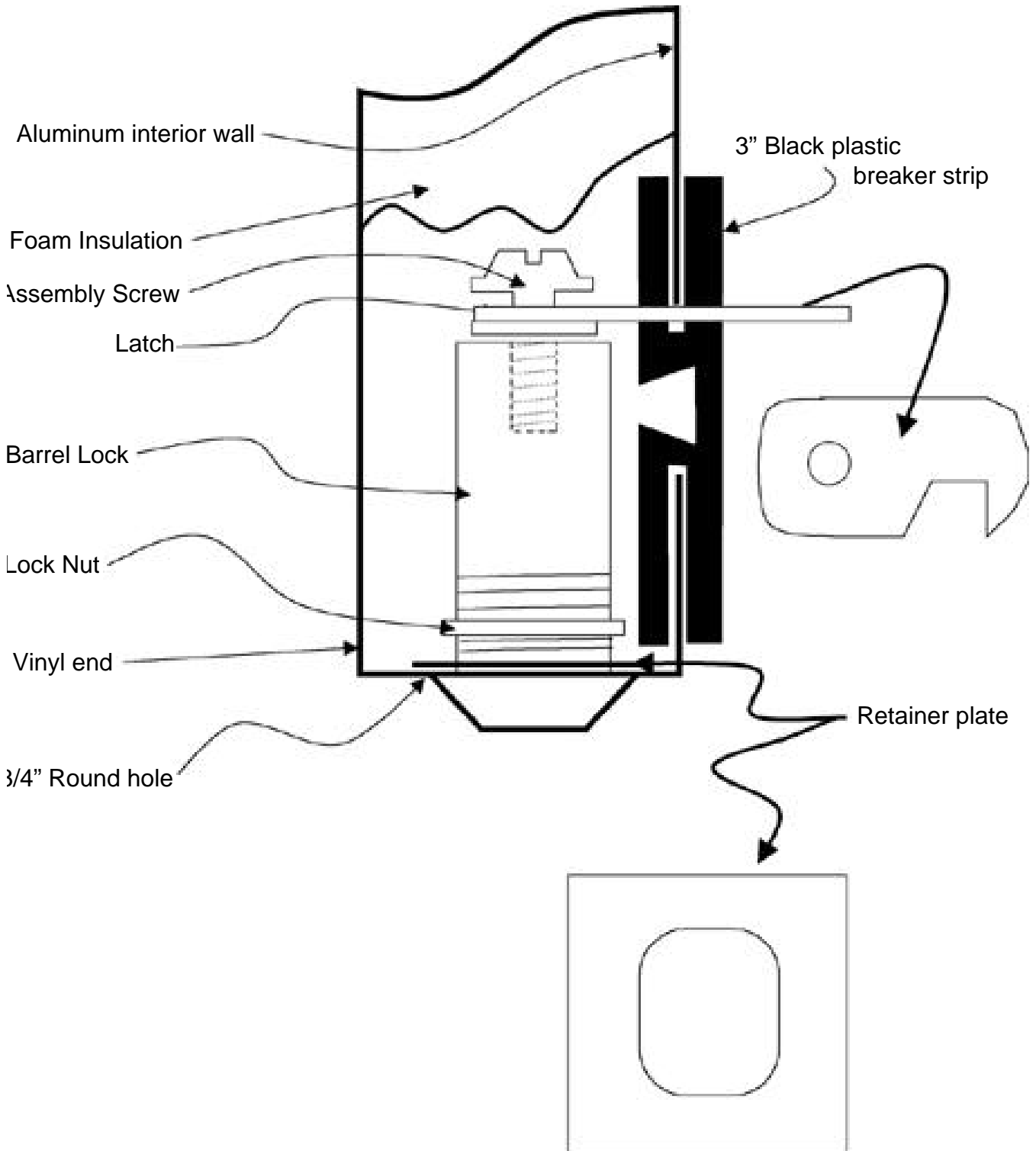

**SLIDE BARREL LOCK (FRONT VIEW)**

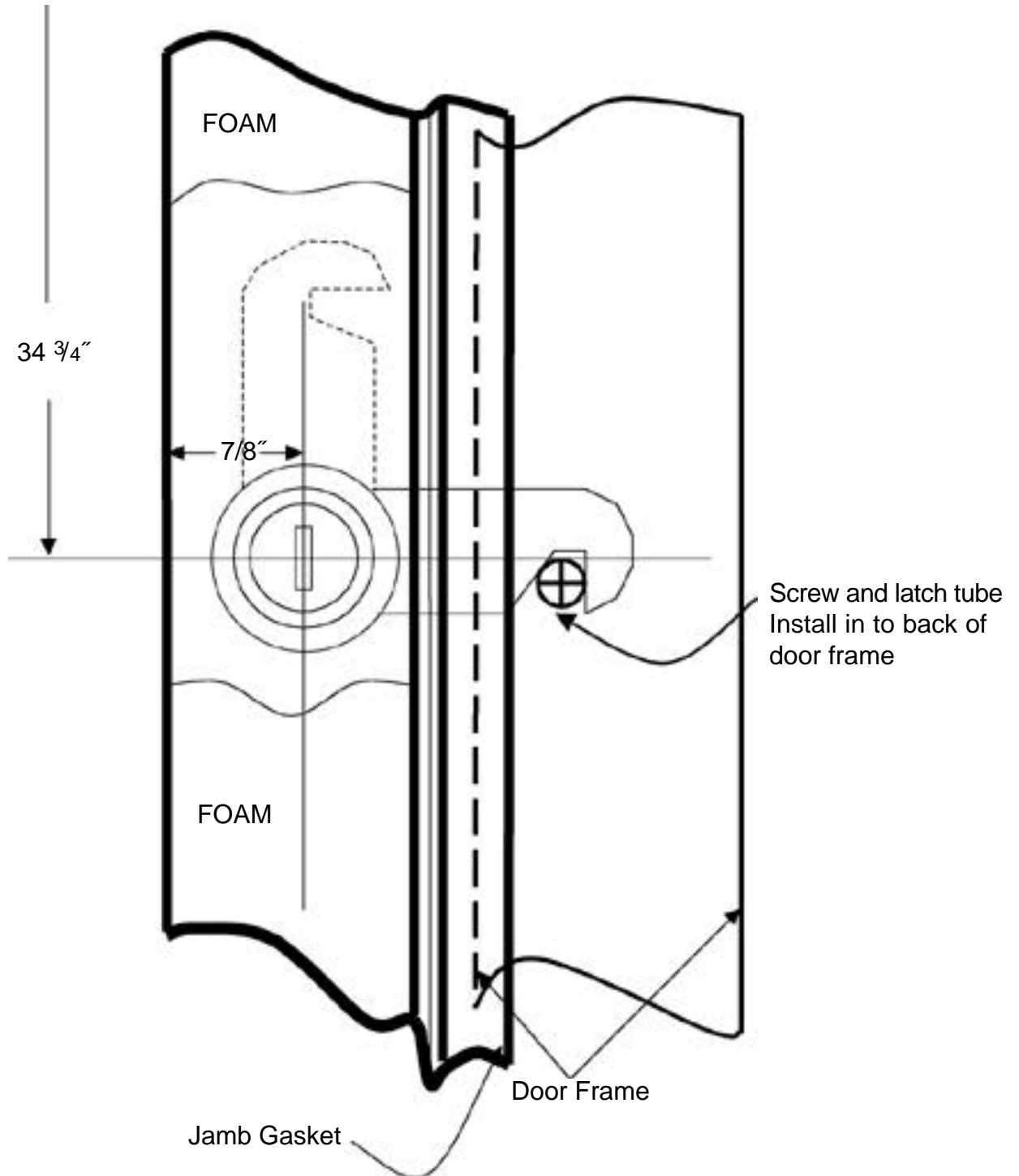

# ▶ **INSTALLATION INSTRUCTION**

## **LOCK INSTALLATION (GDM -5 & GDM-5PT swing door models)**

**REQUIRED TOOLS**

- Tape Measure
- 1/4" Drill
- 2" Saw Drill Hole Saw
- 3/4" Saw Drill Hole Saw
- Straight Edge
- Tin Snips
- Phillips Screw Driver
- File
- Drill Bit For Screws on Lock Cup

**FIRST...**

Before beginning installation, remove front shelf standard from interior wall on handle side of cabinet.

**INSTALLATION**

\_\_\_\_\_ **STEP 1** \_\_\_\_\_

Drill 3/4" hole on outer cooler wall of foam. (Do not penetrate inner wall). (See diagram) Center point of hole is 2 1/4" from front of cooler (including plastic trim) and 13 3/8" from bottom of cooler.

\_\_\_\_\_ **STEP 2** \_\_\_\_\_

Drill 2" hole on inner cooler wall, centered over 3/4" hole. Drill just deep enough to accommodate white-metal backing plate.

**CAUTION**

**Do Not Drill Too Deep.**

\_\_\_\_\_ **STEP 3** \_\_\_\_\_

Remove insulation so white-metal backing plate will fit in hole.

\_\_\_\_\_ **STEP 4** \_\_\_\_\_

Check fit of locking cylinder after inserting through the outer cooler wall. Fill any air space around cylinder and plate with insulation.

\_\_\_\_\_ **STEP 5** \_\_\_\_\_

Place white-metal backing plate over locking cylinder, into 2" hole. Attach lock nut to secure cylinder. Drill holes and attach white metal backing plate to inner cooler wall. (this can be done with screws or pop rivets your option. Parts not provided.)

\_\_\_\_\_ **STEP 6** \_\_\_\_\_

Attach lock arm to locking cylinder with 1/2" screw (provided). Tighten lock nut and screw. Locking mechanism on cooler wall should now be complete. Check operation.

\_\_\_\_\_ **STEP 7** \_\_\_\_\_

Remove rubber gasket from plastic door channel.

\_\_\_\_\_ **STEP 8** \_\_\_\_\_

Determine proper height for strike plate extension to be engaged by lock-arm. Then determine location for two drill holes to attach strike plate to door frame. Drill two 3/16" holes for strike plate through door frame and innermost plastic channel. (CAUTION: Make sure strike plate is positioned on the door so when the door is closed it will pass as close to the edge of the opening as possible without hitting.)

\_\_\_\_\_ **STEP 9** \_\_\_\_\_

Remove portion of the plastic channel wall where the strike plate will be located.

\_\_\_\_\_ **STEP 10** \_\_\_\_\_

Securely attach strike plate to metal frame (through plastic channel) with 3/4" screws (provided).

\_\_\_\_\_ **STEP 11** \_\_\_\_\_

Replace rubber gasket in plastic door channel.

\_\_\_\_\_ **STEP 12** \_\_\_\_\_

Check for proper operation.

\_\_\_\_\_ **STEP 13** \_\_\_\_\_

Install split standard (2 pieces) in place of original one piece standard. Use original mounting holes and secure.

**NOTE**

**Shorter piece should be at top.**

# INSTALLATION INSTRUCTION

## RATCHET LOCK & PLASTIC DOOR STOP - SLIDE DOOR

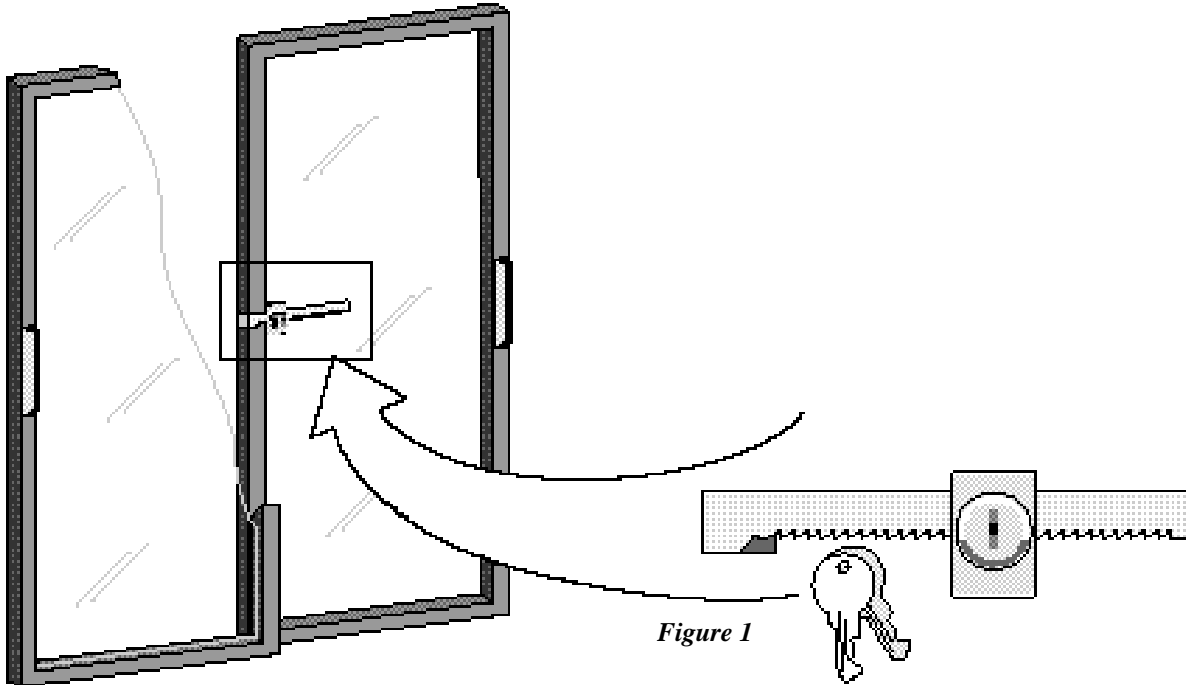

Figure 1

### REQUIRED TOOLS

- Drill With 1/8" Bit
- 1/4" Nut Driver
- Exacto Knife or Razor Blade Knife

### STEP 1

Remove left side door by lifting up and out of bottom track.

### STEP 2

Position ratchet bar over left side of right hand door, centered top to bottom. (see figure 1.)

### STEP 3

Drill through pilot hole in ratchet bar and into door frame with 1/8" drill bit. Anchor by installing 1/4" hex head screw (provided).

### CAUTION

*Do not drill beyond 3/4" to avoid hitting glass insert.*

### STEP 4

Using an Exacto knife or razor blade carefully cut rubber gasket along the edges of the ratchet bar.

### STEP 5

Replace left side door and check slide operation.

**NOTE:**  
*Ratchet bar may have to be bent in slightly so not to impede operation of left hand door.*

### STEP 6

To lock cabinet, slide ratchet lock onto ratchet bar through slot (lock should be oriented with slot towards top of lock). (see figure 2.)

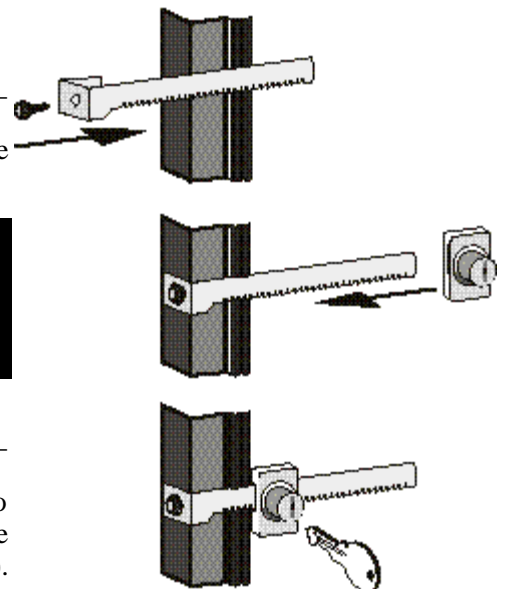

Figure 2



## INSTALLATION INSTRUCTION

### RATCHET LOCK & PLASTIC DOOR STOP - SLIDE DOOR ...Continued

#### Plastic Door Stop Installation Instruction

(Unnecessary if factory installed)

#### REQUIRED TOOLS

- Drill With 1/8" Bit
- Phillips Head Screwdriver

#### STEP 1

Remove left side door by lifting up and out of bottom track.

#### STEP 2

Position the plastic door stop centered in the front door channel and mark it. Center within the confines of the door that was removed.

#### STEP 3

Peel backing from double-sided tape and position on previously marked spot.

#### STEP 4

Drill 1/8" holes using the pre-drilled holes of the plastic door stop as a template.

#### STEP 5

Install phillips counter-sunk screws provided. (see figure 3.)

#### STEP 6

Replace left side door and check slide operation. If door stop impedes closing of left hand door, remove door, detach plastic door stop and remove one layer or piece of the door stop and reinstall.

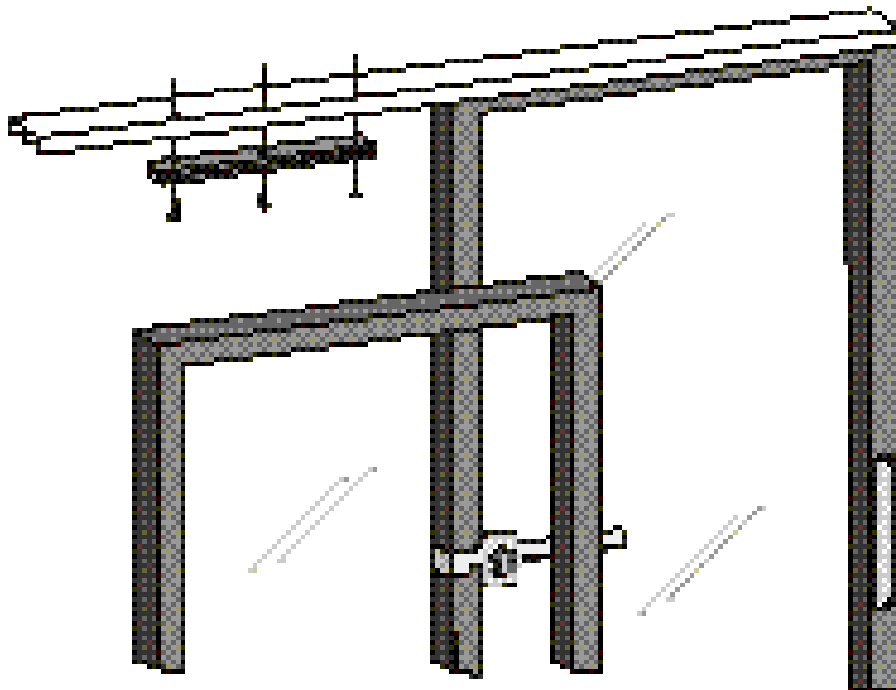

Figure 3

**NOTE:**  
*Length of door stop and  
 number of screws determined  
 by cooler model*

**INSTALLATION INSTRUCTION**  
**LOCK INSTALLATION - TD Models**



**REQUIRED TOOLS**

- Phillips screwdriver

**STEP 1**

Remove original lid handle and replace with notched handle provided.

**STEP 2**

Close lid completely. Slide ratchet bar through notched handle so the bar wraps around front rail assembly.

**STEP 3**

Slide locking cylinder on ratchet bar until snug against handle. Lid is now in locked position.



# ***GENERAL INSTRUCTIONS***

In this section you find many different instructions from how to install castors to how to install vandal panels. If there are any questions or we do not cover your needs in this section, please call.

**Technical Service 1-800-325-6152**



## INSTALLATION INSTRUCTION

### OVERSHELF OPTION - TSSU, TWT, TUC

Congratulations on your purchase of an accessory that has been designed to efficiently assist your food preparation. The following instruction has been written to assist you in your overshelf installation.

#### KIT CONTENTS

- Shelf, 1 ea.
- Shelf supports, 2 ea. (60" models offer 3 ea.)
- 1/4-20x1" Hex Head Bolt, 4 ea.
- 1/4-20x1-1/2" Hex Head Bolt, 4 ea. (60" models offer 6 ea.)
- 1/4" Flat Washer, 4 ea. (60" models offer 6 ea.)

#### REQUIRED TOOLS

- 7/16 Wrench

#### INSTALLATION

##### STEP 1

Place one flat washer on each of the 1/4-20x 1-1/2" hex head bolts and insert one of these assemblies into each mounting hole, located on the longer section of the square shelf support.

##### STEP 2

Hold the shelf support next to the threaded holes that are located along the edge on the back of the cabinet, (60" models have a third shelf support that is located near the center of the cabinet back).

##### STEP 3

Carefully thread the 1/4-20 x 1-1/2" bolts into these threaded holes until the supports make contact with the cabinet and the bolts are hand tight.



Figure 1.

##### STEP 4

Repeat steps 2 and 3 to install the second shelf support, (for 60" models, repeat steps 2 and 3 for the third support).

##### STEP 5

Hold the shelf up between the two mounted shelf supports and thread one 1/4-20x1" hex head bolt into each of the two threaded holes that are located on the inside surface of each shelf support, (for the 48" and 60" models, have someone help hold the shelf in position). Thread each bolt until the shelf is drawn against the shelf support and the bolt is hand tight.

##### STEP 6

Adjust the shelf assembly so that the shelf supports are vertical and the shelf is flat

##### STEP 7

Firmly tighten each bolt using the 7/16 wrench.

#### CAUTION

*Do not place more than 100 lbs. of weight upon the overshelf, and never stand on the overshelf.*

# INSTALLATION INSTRUCTION

## INSTALLING THE CRUMB CATCHER / ACCESSORY FOR THE TSSU SERIES

### CRUMB CATCHER INSTALLATION

This instruction is *True's* recommended procedure for installing the crumb catcher option.

### REQUIRED TOOLS

- Pencil or Marker
- Phillips Screwdriver
- Adhesive Tape or Equivalent
- Power Drill and 1/4" drill bit

### TEMPLATE

#### STEP 2

Place the crumb tray on the cabinet counter-top so that it is equally positioned at each end.

#### STEP 3

Use adhesive tape to temporarily hold the crumb tray in position while you mark with a pencil the hole location on the stainless steel counter-top.

### ANCHORING THE CRUMB CATCHER

#### STEP 5

Remove any small burs from around the holes that have been drilled.

#### STEP 6

The plastic inserts are now ready to be installed. Push the plastic insert into one of the 1/4" diameter holes.

#### STEP 7

With all the plastic inserts installed, place the crumb catcher on the counter-top and fasten using the screws provided.

#### STEP 8

Place the 3/4" thick cutting board provided with this kit on the cabinet counter-top.

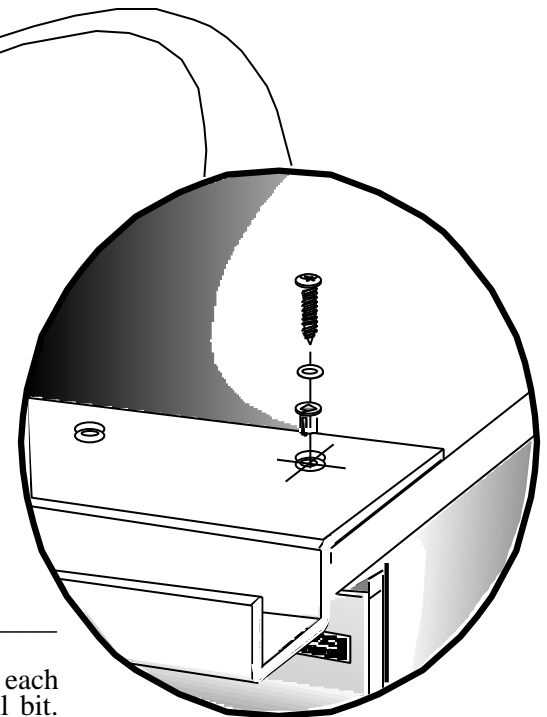
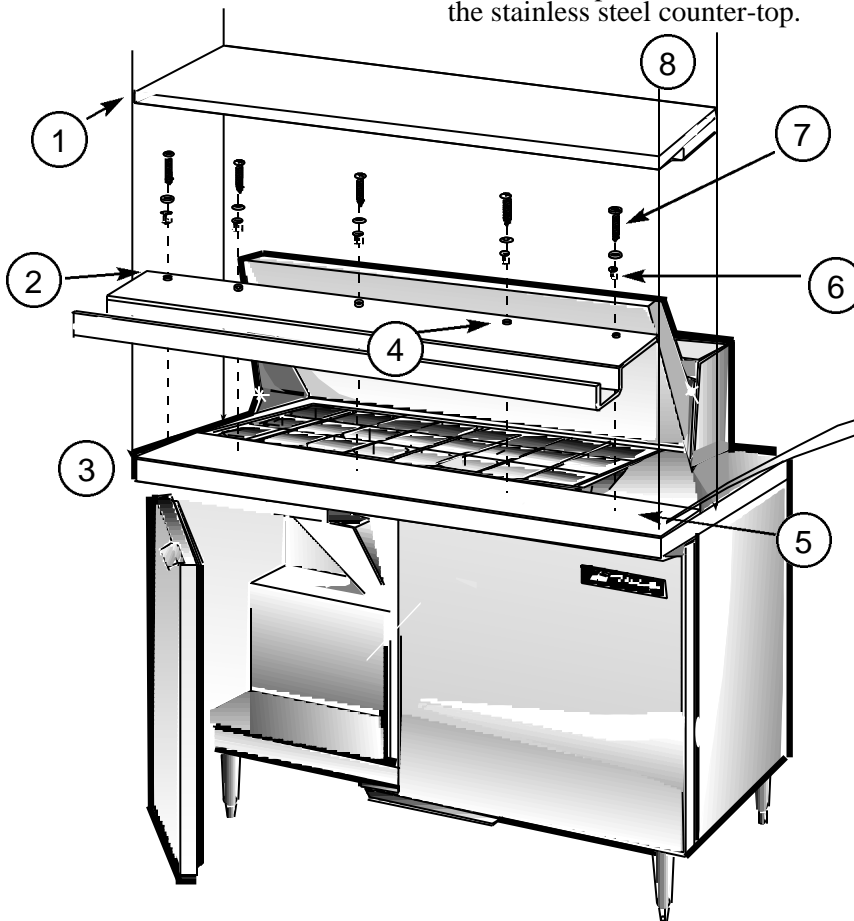

Figure 1.

### INSTALLATION INSTRUCTION

#### STEP 1

Remove the white plastic cutting board provided with the cabinet from the counter-top.

#### STEP 4

Remove the crumb tray and drill each hole using the 1/4" diameter drill bit. Be careful not to allow the drill to wander and scar the countertop.

## INSTALLATION INSTRUCTION

### FIELD INSTALLING THE TSSU SERIES 19" CUTTING BOARD

This instruction is *True's* recommended procedure for installing the 19" cutting board option.

#### REQUIRED TOOLS

- Pencil or Marker
- Flathead Screwdriver
- Adhesive Tape or Equivalent
- Power Drill
- Adjustable Wrench

#### LOCATION

Align the predrilled cutting board holes with the locating pins positioned on the stainless working surface.

#### SURFACE PREPARATION

##### STEP 1

Tape off both sides of work surface so that errant drilling will not mark the side of the cabinet.

##### STEP 2

Place the anchor bracket over the top of the cutting board edge, pulling forward until bracket backstop is seated firmly against the cutting board edge. Use bracket screw holes as a template for drilling.

##### STEP 3

Pencil mark drill hole. Using the #2 or 15/64 bit provided, drill through the metal thickness, stop, and pull out.

##### STEP 4

Assemble riv-nut tool provided and lubricate, (WD-40, etc.), the threads. Ensure that the flange of the rivnut seats against the knurled edge.

##### STEP 5

Insert allen wrench into top of crimping tool and place entire rivnut assembly into recently drilled holes.

##### STEP 6

Secure crimping tool with a wrench and turn allen wrench in a clockwise

rotation until resistance is felt. (overtightening will strip rivnut)

##### STEP 7

When minor resistance is felt, rivnut has expanded to fill the drill hole. Remove tape from sides. Repeat steps 2 through 7 for each of the four anchor positions, and replace anchor bracket. Use a slotted screwdriver to tighten thumb screws.

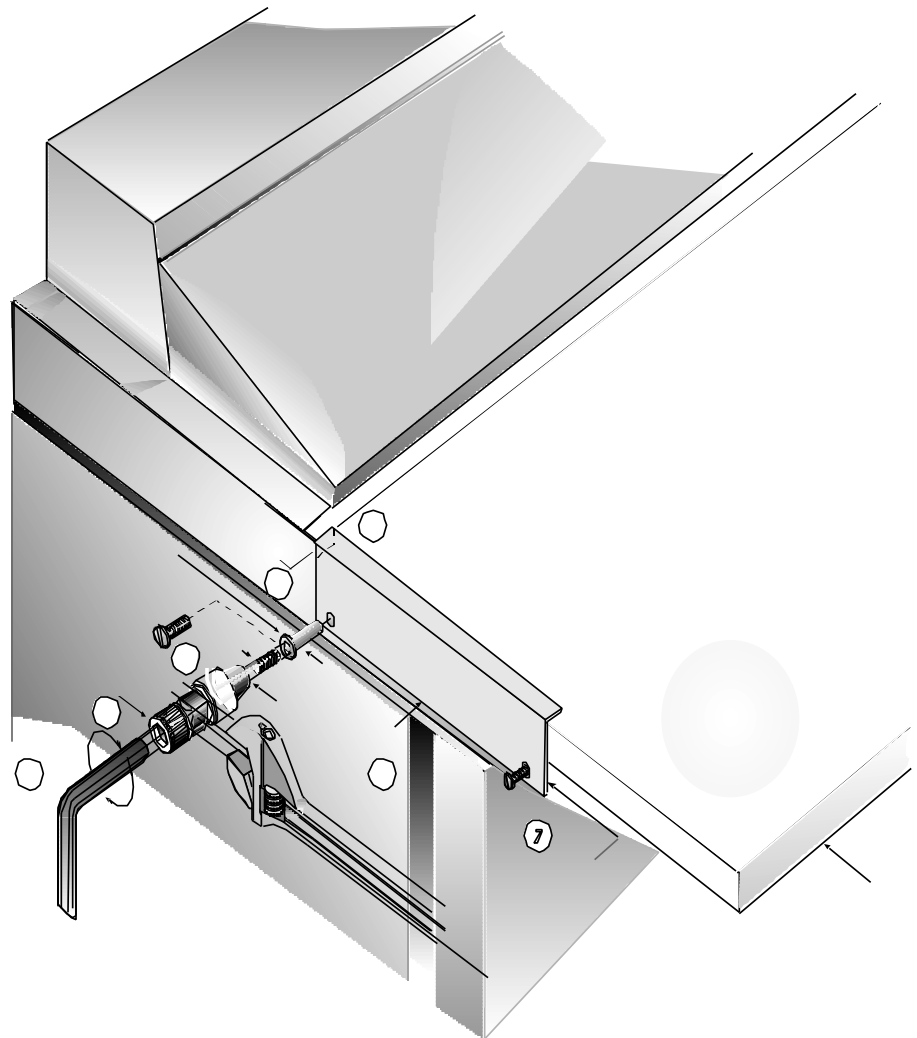

Figure 1.

## INSTALLATION INSTRUCTION

### ANCHORING THE TSSU HOOD COVER

*This is True's recommended procedure for installing the fasteners required to connect the sandwich salad hood cover to the hood. See callout #1 on the illustration.*

#### ASSEMBLY

##### STEP 1

Locate the hood cover, (packaged within the cardboard container on top of the salad sandwich unit), and position under the hood.

##### STEP 2

Remove the slotted thumb screw from hood by backing out the factory installed, slotted thumb screw. See diagram of slotted thumb screw and callout #2

##### STEP 3

Place hood cover into final position, (beneath hood), align hood hinge pin with anchor hole on hood cover and re-attach fastener by replacing thumb screw into hinge pin.

##### STEP 4

Repeat procedure for both ends of hood.

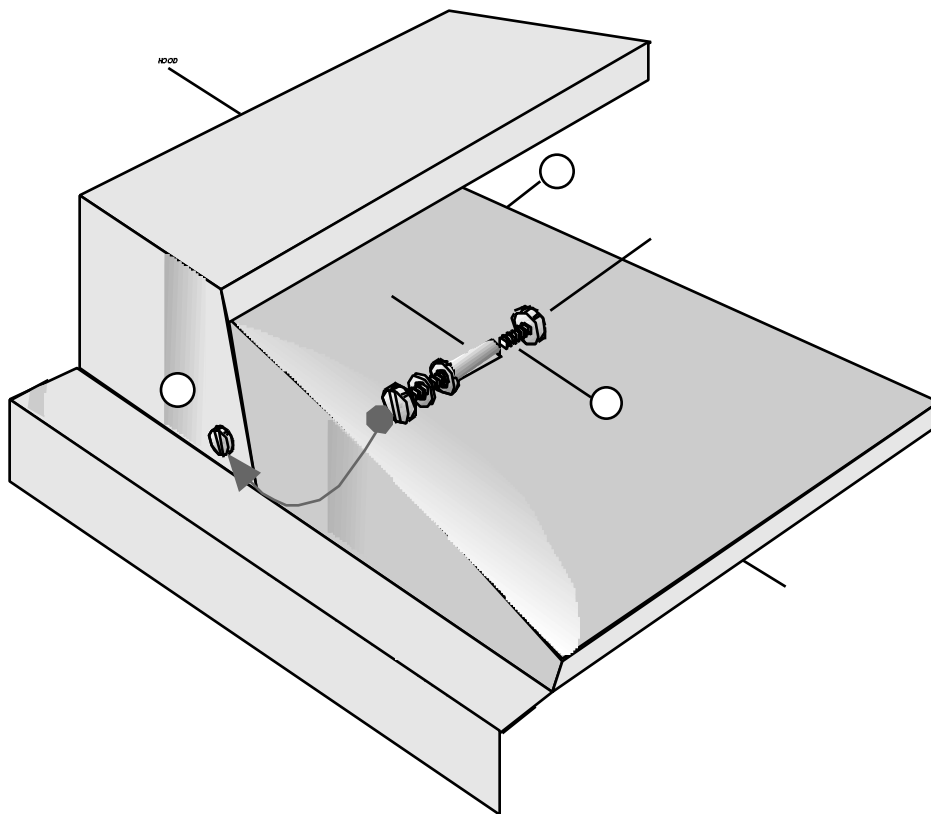

## INSTALLATION INSTRUCTION

### INSTALLING THE TPP SERIES SERVICE SHELF (prior to NSF-7 recessed pan design)

#### REQUIRED TOOLS

- Pencil or Marker
- Slotted Screwdriver
- Center Punch
- Adhesive Tape or Equivalent
- Power Drill With 11/32" Bit
- Adjustable Wrench
- Pilot hole drill bit

#### STEP 1

##### SURFACE PREPARATION -

Mask off the mounting surface of your Pizza Prep or Sandwich/Salad unit with adhesive tape. (this will prevent scaring on the cabinet surface.)

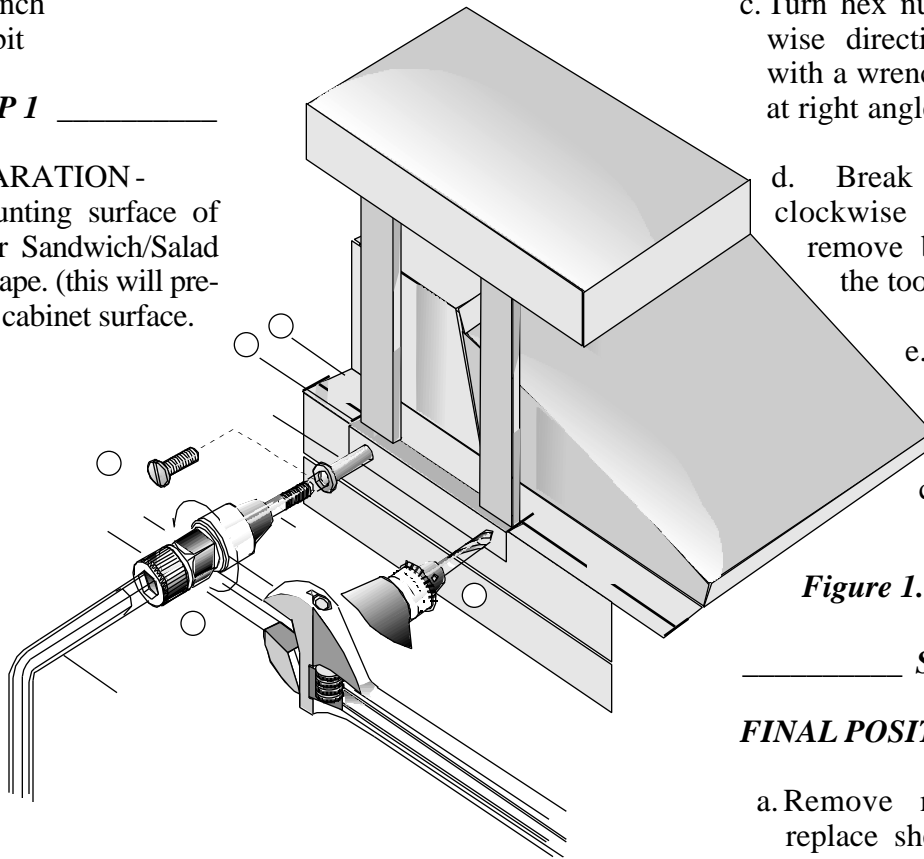

#### STEP 2

Remove service shelf from box and place 3" from the rear of the cabinet (for sandwich/salad units) and 3 3/4" from the front (for pizza prep units) rivnut will strip out.

#### STEP 3

a. Using the predrilled holes of the service shelf as a template, place a pencil mark in each of the mounting holes.

b. Remove the service shelf.

c. Lightly punch a starter mark and drill a pilot hole in each of the two mounting areas. (be careful not to drill beyond an inch and three quarters.

d. Using a 11/32" drill bit, complete the hole.

#### STEP 4

a. Thread the 1/4 - 20 rivnut on the pull-up stud of the rivnut tool until tight and insert into drilled hole.

b. Place hex wrench in the socket of the jackscrew and hold stationary.

#### CAUTION

**Do not turn hex wrench or rivnut will strip out.**

#### STEP 5

c. Turn hex nut in a counterclockwise direction, two full turns, with a wrench while holding tool at right angles to the work area.

d. Break nut loose with a clockwise movement, and remove both wrenches from the tool.

e. Remove rivnut tool from the rivnut by revolving entire tool in counterclockwise direction.

Figure 1.

#### STEP 6

##### FINAL POSITIONING -

a. Remove masking tape, and replace shelf. Seal bracket if required.

b. Align mounting holes of shelf with rivnut holes and screw 1/4 - 20 round head bolts into threaded rivnuts.

## FIELD INSTALLING THE TPP SERVICE SHELF

### REQUIRED TOOLS

- Pencil or Marker
- Slotted Screwdriver
- Center Punch
- Power Drill
- Masking tape

### SURFACE PREPARATION

#### STEP 1

Tape off both sides of the elevated ingredient pan area where the over-shelf legs will be anchored. (this, so that errant drilling will not mar the side of the cabinet).

#### STEP 2

Remove service shelf from box and place shelf legs on top of mounted cutting board. Legs that measure 18" (shorter legs), are to be positioned toward the front of prep table.

#### STEP 3

Center legs on elevated ingredient pan area - left to right. The shelf is not the exact width of the pizza prep table.

#### STEP 4

Using a level placed on top of the service shelf, adjust, (raise or lower) the rear legs for anchor positioning.

#### STEP 5

Using the pre-drilled holes of the service shelf as a template, place a pencil mark on the elevated surface. Create a pilot hole with a nail or small drill bit.

#### STEP 6

Assemble riv-nut tool provided and lubricate, (WD-40, etc), the threads. Ensure that the flange of the riv-nut seats against the knurled edge.

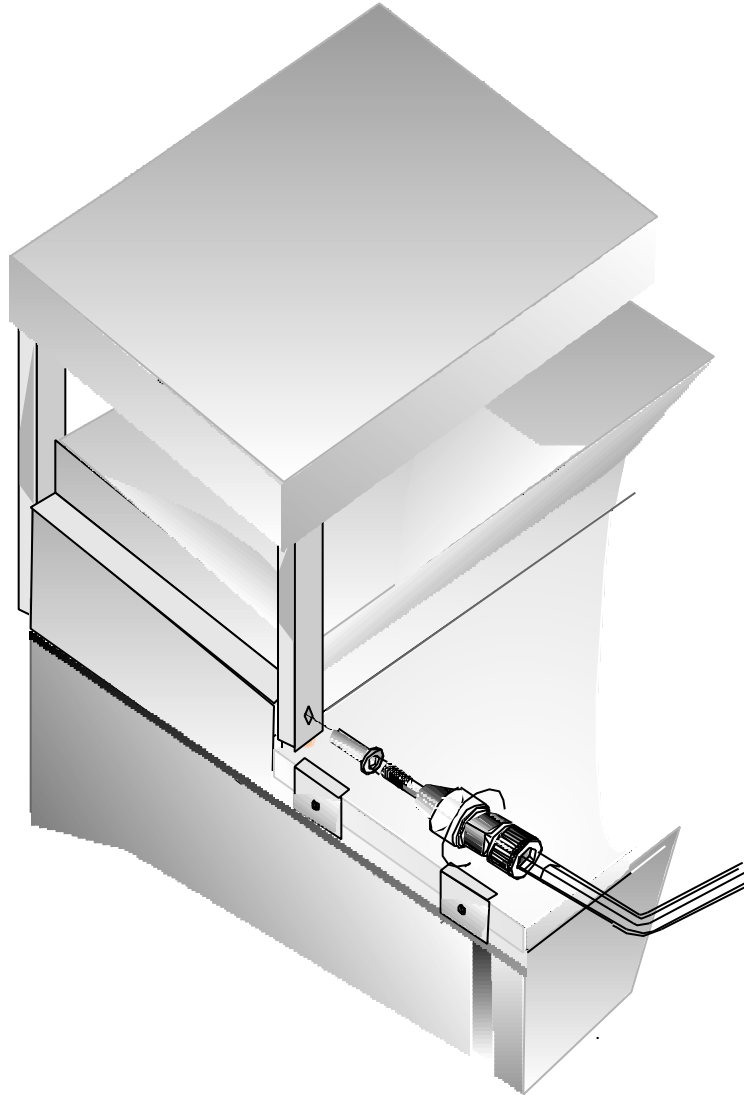

#### STEP 7

Insert allen wrench into top of crimping tool and place entire riv-nut assembly into recently drilled holes

#### STEP 8

Secure crimping tool with a wrench and turn allen wrench in a clockwise rotation until resistance is felt (overtightening will strip riv-nut)

#### STEP 9

When minor resistance is felt, riv-nut has expanded to fill the drill hole. Remove tape from sides. Repeat these steps each of the four anchor positions, and replace anchor bracket. Use a slotted screwdriver to tighten thumb screws.

#### NOTE:

**Hardware is tapped to rear leg of service shelf.**

## INSTALLATION INSTRUCTION

### SNEEZEGUARD OPTION - TSSU

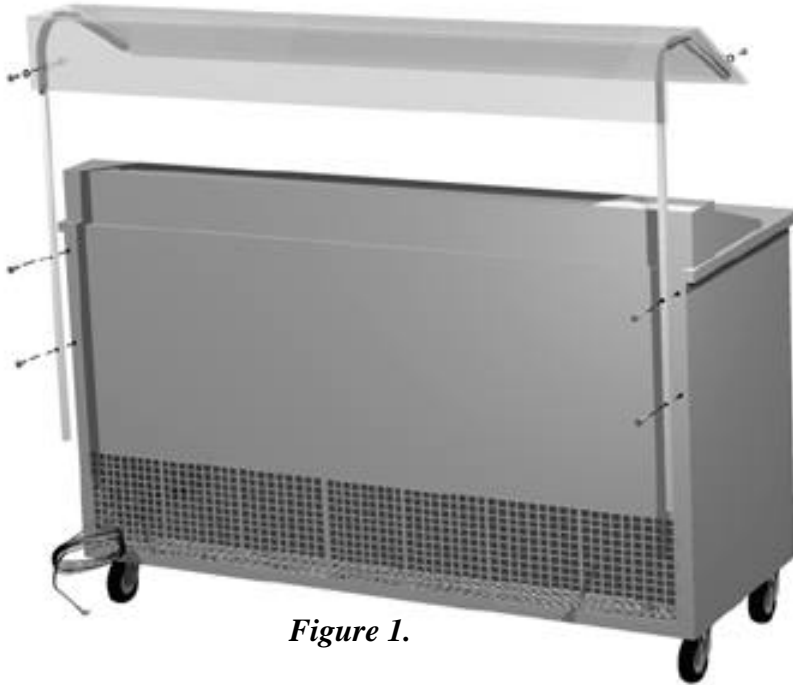

Figure 1.

### SNEEZE GUARD ASSEMBLY

#### KIT CONTENTS

- Clear Plastic Shield, 1 ea.
- Supports, 2 ea.
- 1/4-20x1-1/2" Hex Head Bolt, 4 ea.
- 1/4" Flat Washer, 4 ea.
- #8-32 Knurled Waferhead Screw, 4 ea.

#### REQUIRED TOOLS

- 7/16 Wrench

#### INSTALLATION

##### STEP 1

Place one flat washer on each of the 1/4-20" hex head bolts.

##### STEP 2

Insert one 1/4-20 x 1-1/2" bolt into each of the two holes on the support component and position the support next to the two threaded inserts that are mounted to the outer edge on the back of the TSSU cabinet.

##### STEP 3

Screw the bolts into the threaded inserts until they are hand tight.

##### STEP 4

Repeat steps 2 and 3 for the remaining support components which will be mounted to the other end of the cabinet back.

##### STEP 5

Remove the protective covering from the clear plastic shield so that it rests on top of the two support components. Be careful not to scratch the plastic shield.

##### STEP 6

Secure the clear plastic shield to the supports by installing the four #8-32 knurled waferhead screws into the threaded inserts that are located; one on the top, and one on the rear surface of each support component. Hand tighten these four screws.

##### STEP 7

Adjust the two support components so that they are positioned straight up, and tighten the four 1/4-20 x 1-1/2" hex head bolts until the support components are held firmly in position.

#### CLEANING AND CARE

*The support components are made of stainless steel and may be cleaned with any food service stainless steel cleaner.*

*The clear plastic shield should be cleaned only with mild soap, warm water and a soft cloth.*

# Castor or Leg Frame Installation

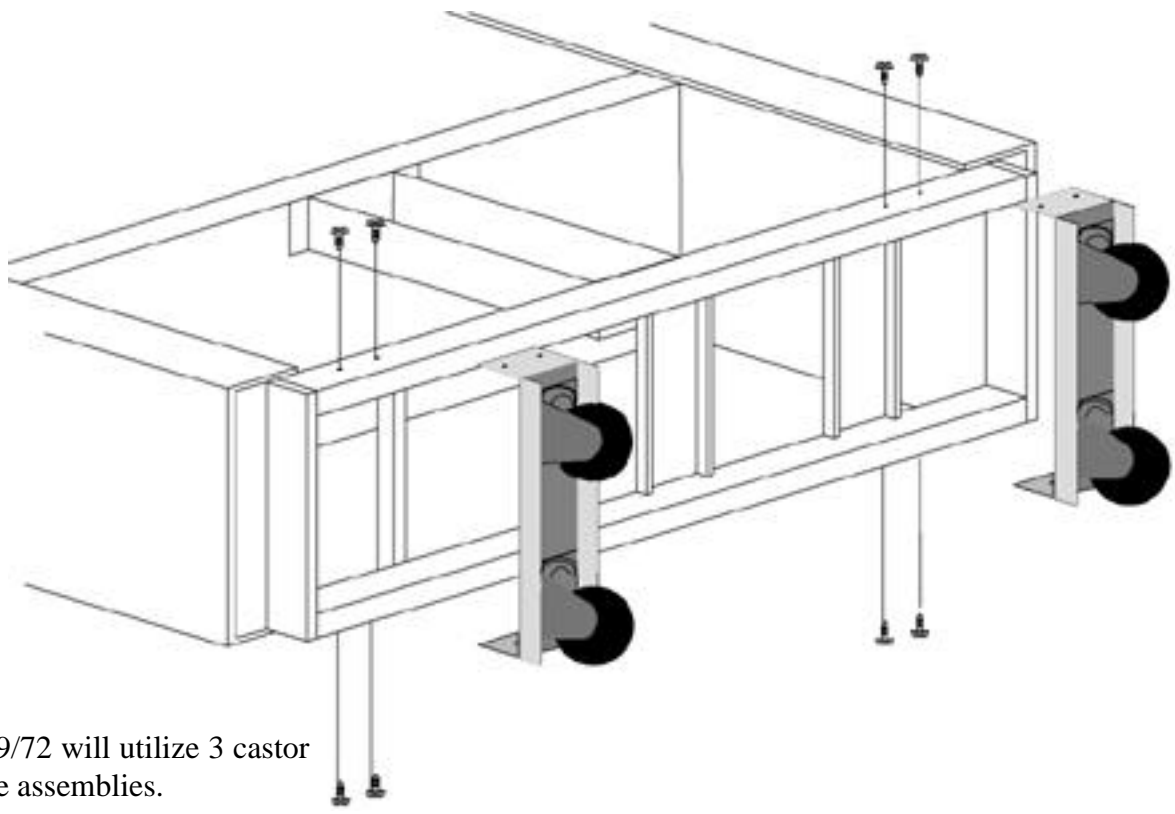

GDM-61/69/72 will utilize 3 castor or leg frame assemblies.



# ▶ INSTALLATION INSTRUCTION

## GDM-33CPT Castor Mounting Assembly

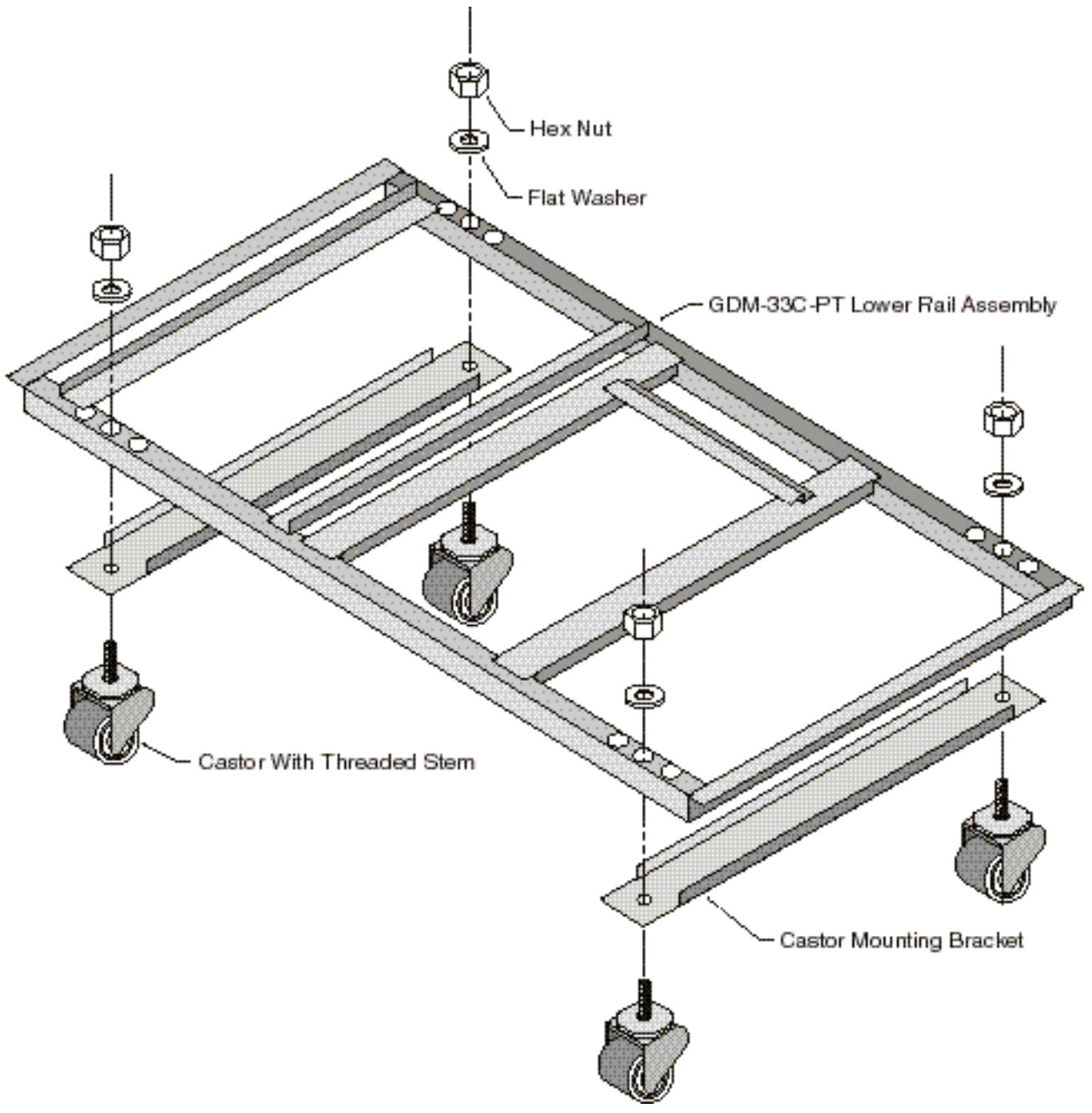

## INSTALLATION INSTRUCTION

### TDD-1 CO<sub>2</sub> Knock-out

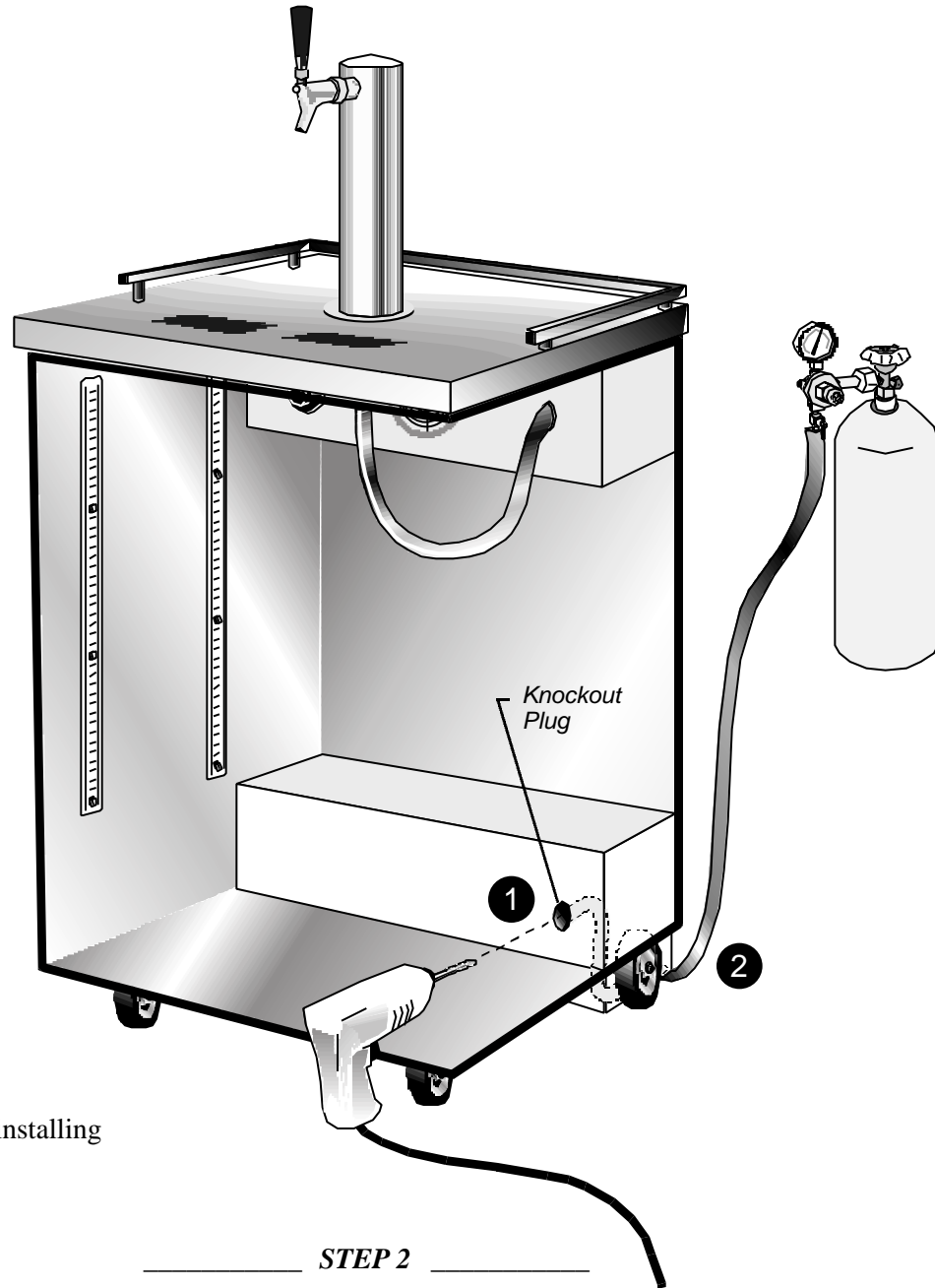

This instruction is True's recommended procedure for installing a remote CO<sub>2</sub> container.

#### REQUIRED TOOLS

- Pliers
- Power Drill
- Silicone Sealer
- Drill bit, 1/2"

#### STEP 2

Use drill and bit to bore hole straight back through wall into compressor compartment.

#### STEP 1

Remove black knockout plug with a pair of pliers.

#### STEP 3

Snake CO<sub>2</sub> line through hole down and around exiting behind rear castor underneath rear grill.

#### STEP 4

Seal hole around CO<sub>2</sub> line with silicone sealer to prevent cold air leakage.

## INSTALLATION INSTRUCTION

### TDD-2,3,4 (and Club Top models) CO<sub>2</sub> Knock-out

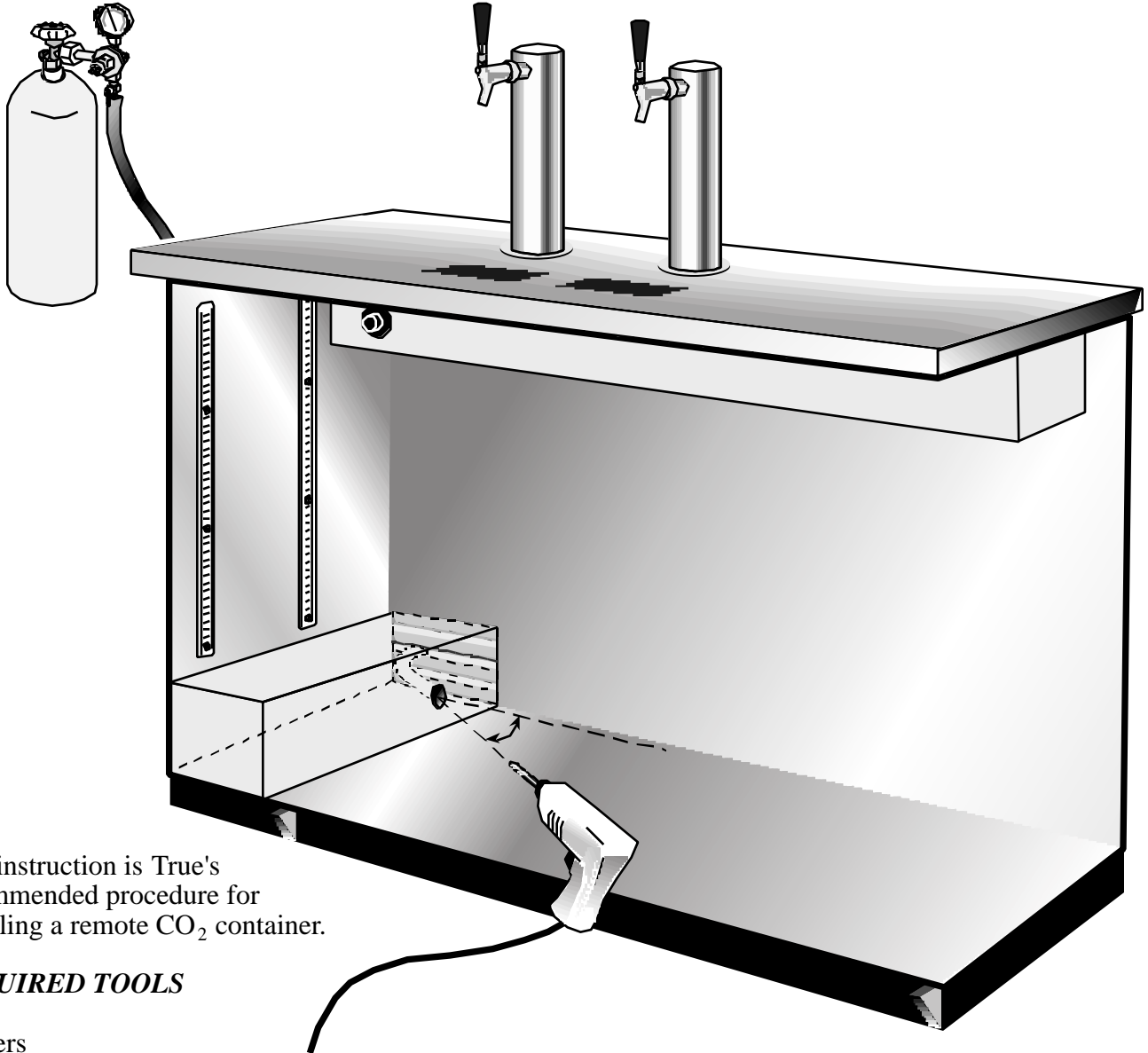

This instruction is True's recommended procedure for installing a remote CO<sub>2</sub> container.

#### REQUIRED TOOLS

- Pliers
- Power Drill
- Silicone sealer
- Drill bit, 1/2"

#### STEP 1

Remove black knockout plug with a pair of pliers.

#### STEP 2

Use drill to bore hole through insulation while holding tool at a 30° angle, this should line up with a pre-punched hole in the compressor compartment.

#### STEP 3

Snake CO<sub>2</sub> line through knockout hole and newly drilled hole and route through rear grill louvers.

#### STEP 4

Seal hole around CO<sub>2</sub> line with silicone sealer to prevent cold air leakage.

## INSTALLATION INSTRUCTION

### Vandal Panel Installation for a GDM-33CPT-54

#### Kit Materials

1. (16) Pop Rivets
2. (8) Mounting Brackets
3. (2) Vandal Panel

#### STEP 1

Two Mounting Brackets need to be positioned on the upper left and right hand corners of the cabinet. The Mounting Brackets must be off  $1/16$ " down from the top of the cabinet. See Illustration one. Drill holes with  $7/32$  drill bit and attach bracket via pop rivets.

#### STEP 2

The two other Mounting Brackets are mounted  $32\ 7/8$ " from the top of the cabinet to the bottom of the Mounting Bracket. The two bottom brackets must be installed facing the opposite direction from the top two brackets already installed in Step A. See Illustration 2.

#### STEP 3

The Vandal Panel slides down on top of the Top Mounting Brackets (see Illustration 3). Then the bottom brackets lock onto the Vandal Panel.

#### STEP 4

Repeat Procedure for installation of other vandal panel on back of cabinet.

Illustration 1

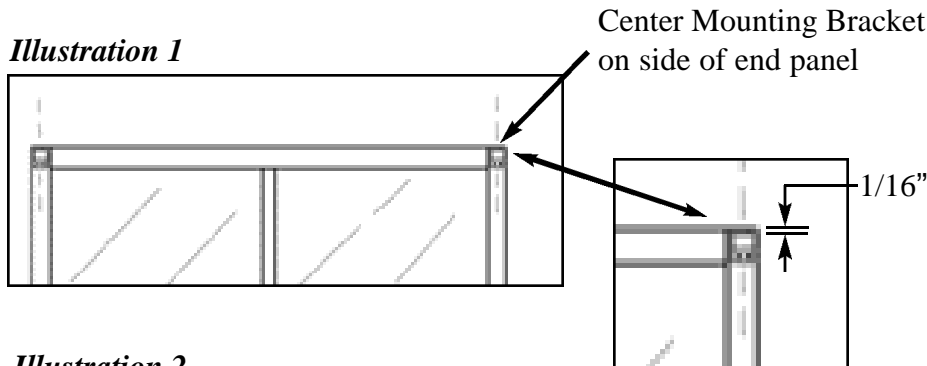

Illustration 2

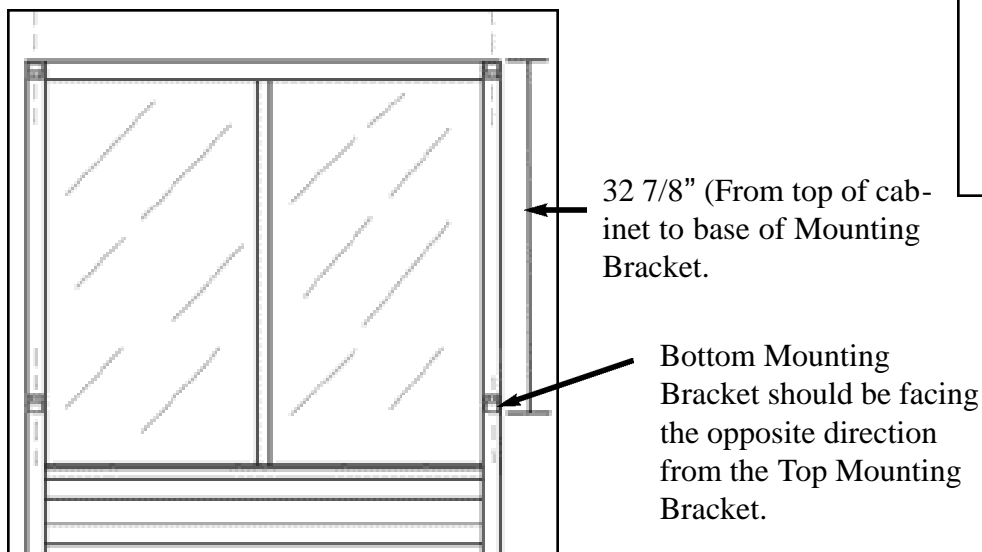
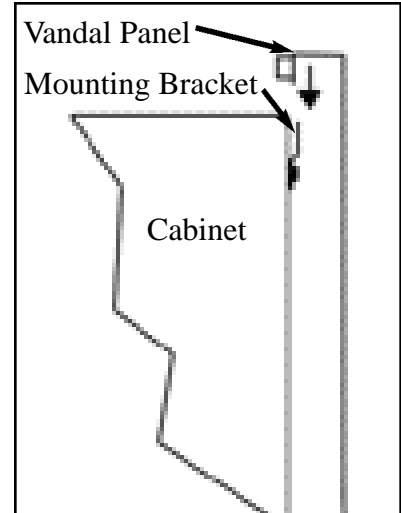

Illustration 3



# INSTALLATION INSTRUCTION

## Vandal Panel - GDM-69

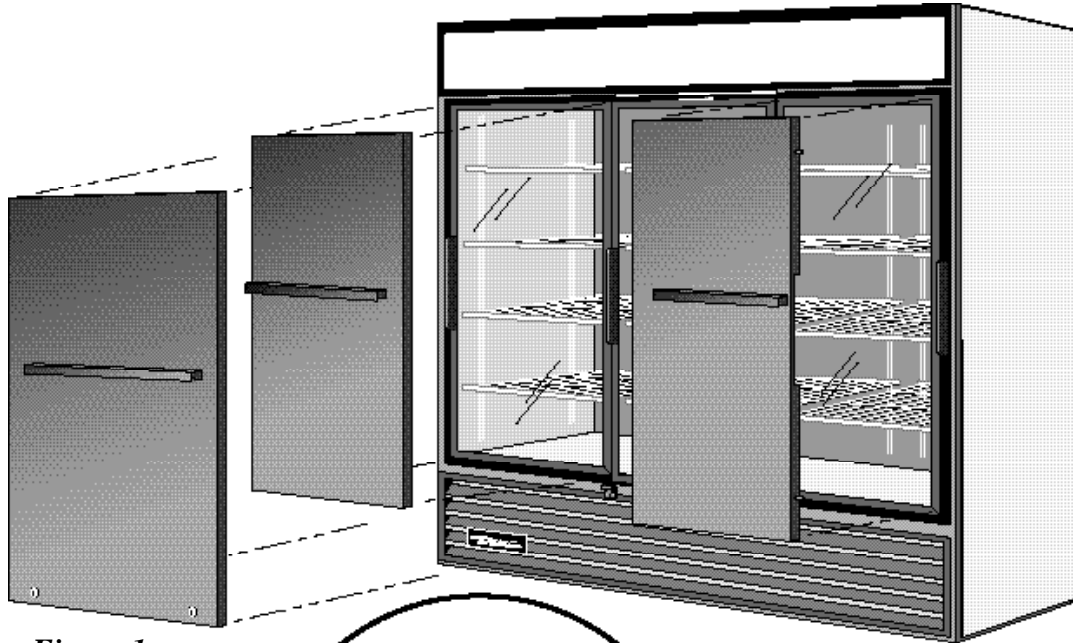

Figure 1.

### REQUIRED TOOLS

- Drill - 1/4" Bit  
- 3/16" Bit
- Pop-Rivet gun
- Tape Measure

#### STEP 1

Unplug the cooler.

#### STEP 2

Position bracket "A" directly under the sign panel trim with the lip down. (See figure 2.)

#### STEP 3

Center the bracket on the front of the cooler.

#### STEP 4

Drill five holes in the cooler front by transferring them through the pre-drilled bracket.

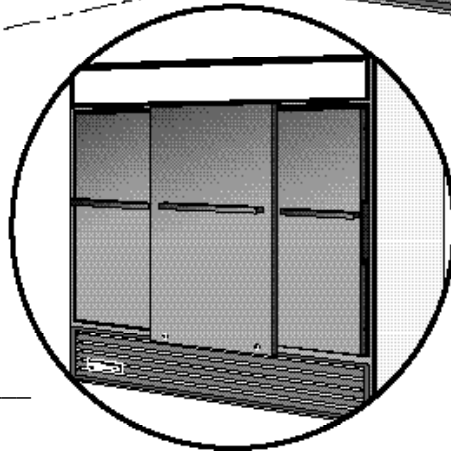

#### STEP 5

Pop-rivet the bracket in place.

#### STEP 6

The two brackets "B" will be mounted on the front of the cooler, directly below the bottom door tracks.

#### STEP 7

Position one bracket "B" so that the center of the bracket is 26 1/2" from the right hand edge of the cooler. Located the second bracket "B" so that it is 26 1/2" from the left hand edge of the cooler. (See figure "2")

#### STEP 8

Check the height of the brackets before drilling.

The dimension from the top of the lip on bracket "A" to the bottom of the lip on bracket "B" must be 53". (See figure "2")

### IMPORTANT

*Check all dimensions carefully before drilling*

# INSTALLATION INSTRUCTION

## Vandal Panel - GDM-69 ...continued

### STEP 9

When in place, drill with 3/16" bit and fasten with rivets.

#### NOTE:

*The right side of the cooler is determined when facing the cooler.*

### STEP 10

Two (1/4") holes need to be drilled in both the left and right vertical door tracks. Lay the "left side" template against the front and inside edge of the cooler. The bottom edge of the template must rest on the top of the lower plastic door track. (See figure "3".) Transfer the holes from the template into the side wall of the cooler. Drill the holes only 1" deep. Do not drill through the walls.

Repeat this operation for the right side. (templates are marked left and right and the top is also indicated.)

### To Mount The Panels

#### STEP 1

Slide the right hand panel into place by guiding the two pins into the drilled holes in the vertical door track. Push the panel to the right and back until the foam tape rest against the center door. Repeat for the left panel.

#### STEP 2

Hang the lip of the center panel on the lip on bracket "A".

#### NOTE:

*Panels may be shipped in the locked position - in this case turn lock to fit panel over bracket "B"*

#### STEP 3

Lock in place by turning the key locks to engage brackets "B".

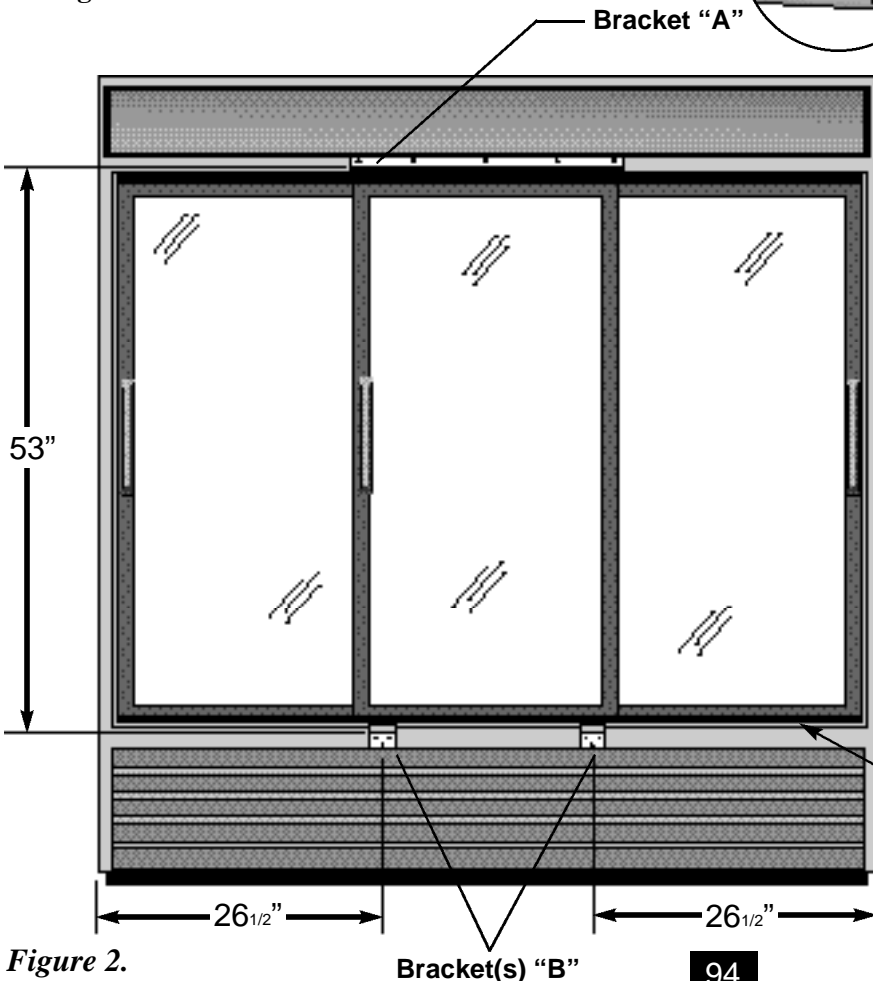
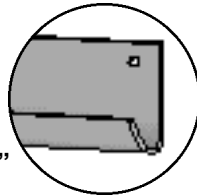

Figure 2.

Bracket(s) "B"

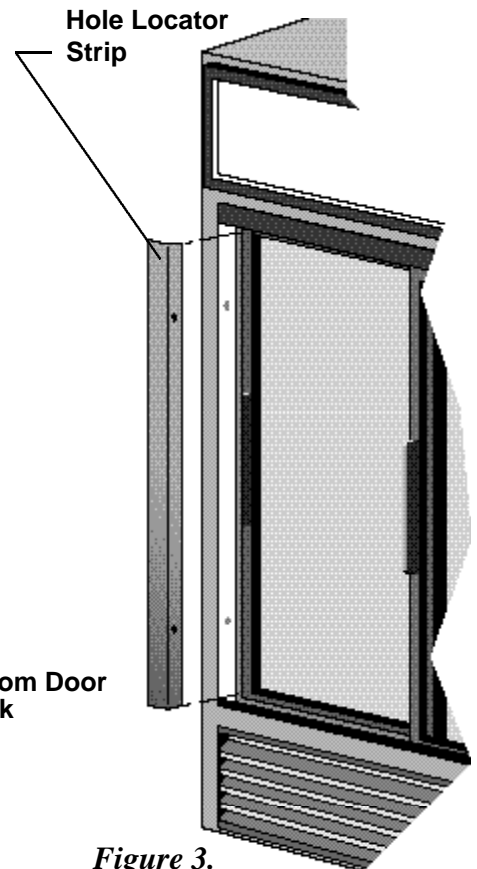

Figure 3.

# **Notes**



# ***TROUBLESHOOTING***

This section provides troubleshooting instructions that will help a qualified service technician diagnose any problem you may be having with your cabinet. Because there is risk of electrocution if they are not followed correctly, a qualified service technician must be used when following these steps. For diagnosing unusual problems or if there are questions regarding these instructions, please call.

**Technical Service 1-800-325-6152**



# INSTALLATION INSTRUCTION

## CALIBRATE TEMPERATURE CONTROL

### REQUIRED TOOLS

- Accurate Remote Reading Thermometer
- 1/4" Nutdriver
- Jeweler Screwdriver

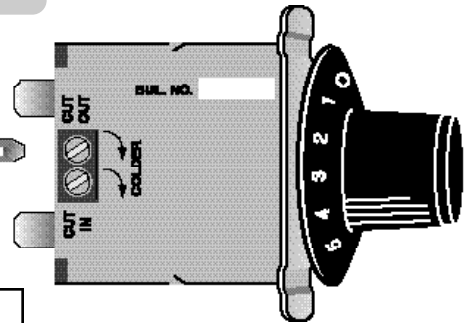
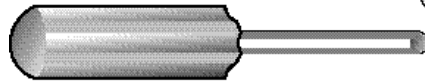

### Refrigerator Instructions

For cooler calibration install thermometer in evaporator coil. Shut door and get true reading of where control is opening and closing. Watch to see at what temperatures compressor cycles on and off. Compare these to design temperature of the control and adjust accordingly.

### Freezer Instructions

For freezer calibration install thermometer next to temperature control bulb (this is an air sensing control). Shut door and get a true reading of where control is opening and closing. Watch to see at what temperature the compressor cycles on and off. Compare these to the design temperature of the control and adjust accordingly.

Temp. Control Part Number	°F Cut In	°F Cut Out
800303	35	14.5
800306	40	18
800312	-8.5	-14.5
800313	36.5	16
800320	32.5	26.5
800325	62	55
800335	38	20
800340	26	10
800395	40	22.8

### STEP 8

Check control operation with thermometer as done prior to adjustment to make sure control is functional as desired.

### Calibration

#### STEP 1

Unplug the cabinet.

#### STEP 2

Set control to setting #9.

#### STEP 3

Remove control from evaporator housing and locate cut in and cut out screws. Refer to *Temperature Control Change-Out Instructions*, page 39-41.

#### STEP 4

Use jeweler screwdriver and adjust control accordingly:

- Adjust screws clockwise for colder.
- Adjust screws counter-clockwise for warmer.

**Note:** 1/4 turn is equal approximately 4 degrees.

#### STEP 6

Re-install control into housing. Refer to *Temperature Control Change-Out Instructions*, page 39-41.

When reinstalling freezer control make sure temperature control wires are being held up so they do not make contact with evaporator heater.

#### STEP 7

Reset control to setting #5.

### Calibration Instructions For 20DT Digital Thermometer

#### STEP 1

Note that each unit is factory calibrated and a glyptol color coded seal is placed on the calibration potentiometer to prevent calibration shift. The color represents date of manufacturer.

#### STEP 2

Immerse the sensor in a known temperature circulated liquid bath, using a mercury glass thermometer to obtain the right temperature, or have a mixture of water and crushed ice (slush) to obtain 32°F (0°C).

#### STEP 3

To recalibrate the thermometer use a small phillips head screwdriver to adjust the potentiometer on the back of the 20DT. Turn clockwise to adjust down and counter-clockwise to adjust up. To re-seal the potentiometer you can use clear nail polish.

**INSTALLATION INSTRUCTION** \_\_\_\_\_  
**CALIBRATE TEMPERATURE CONTROL . . . . . Continued**

Temperature Control Part Number	°F Cut In	°F Cut Out	Old Temperature Control Part Number
800345	-2.5	15.5	
800358	-8.5	-14.5	800312
800366	35	15.5	800303
800369	-2.5	-12.5	See Note*
800371	42	23.5	800395 High Altitude
800382	36.5	17	800313
800383	3	-5.5	800357 / 800399
800393	40	19.5	800306

- Currently being used in several freezer models

# CFC & REFRIGERATION BASICS

## Trouble Shooting and Service Chart

COMPLAINT	POSSIBLE CAUSE	REPAIR
<b>A</b> Compressor will not start - no hum	<ol style="list-style-type: none"> <li>1. Line disconnect switch open.</li> <li>2. Fuse removed or blown.</li> <li>3. Overload protector tripped.</li> <li>4. Control stuck in open position.</li> <li>5. Control off due to cold location.</li> <li>6. Wiring improper or loose.</li> </ol>	<ol style="list-style-type: none"> <li>1. Close start or disconnect switch.</li> <li>2. Replace fuse.</li> <li>3. Refer to electrical section.</li> <li>4. Repair or replace control.</li> <li>5. Relocate control.</li> <li>6. Check wiring against diagram.</li> </ol>
<b>B</b> Compressor will not start - hums but trips on overload protector	<ol style="list-style-type: none"> <li>1. Improperly wired.</li> <li>2. Low voltage to unit.</li> <li>3. Starting capacitor defective</li> <li>4. Relay failing to close.</li> <li>5. Compressor motor has a winding open or shorted.</li> <li>6. Internal mechanical trouble in compressor.</li> <li>7. Liquid refrigerant in compressor.</li> </ol>	<ol style="list-style-type: none"> <li>1. Check wiring against diagram.</li> <li>2. Determine reason and correct.</li> <li>3. Determine reason and replace.</li> <li>4. Determine reason and correct, replace if necessary.</li> <li>5. Replace compressor.</li> <li>6. Replace compressor.</li> <li>7. Add crankcase heater and/or accumulator.</li> </ol>
<b>C</b> Compressor starts, but does not switch off of start winding	<ol style="list-style-type: none"> <li>1. Improperly wired.</li> <li>2. Low voltage to unit.</li> <li>3. Relay failing to open.</li> <li>4. Run capacitor defective.</li> <li>5. Excessively high discharge pressure.</li> <li>6. Compressor motor has a winding open or shorted.</li> <li>7. Internal mechanical trouble in compressor (tight).</li> </ol>	<ol style="list-style-type: none"> <li>1. Check wiring against diagram.</li> <li>2. Determine reason and correct.</li> <li>3. Determine reason and correct, replace if necessary.</li> <li>4. Determine reason and replace.</li> <li>5. Check discharge shut-off valve, possible overcharge, or insufficient cooling on condenser.</li> <li>6. Replace compressor.</li> <li>7. Replace compressor.</li> </ol>
<b>D</b> Compressor starts and runs, but short cycles on overload protector	<ol style="list-style-type: none"> <li>1. Additional current passing through overload protector.</li> <li>2. Low voltage to unit (or unbalanced if three phase).</li> <li>3. Overload protector defective.</li> <li>4. Run capacitor defective.</li> <li>5. Excessive discharge pressure.</li> <li>6. Suction pressure too high.</li> <li>7. Compressor too hot - return gas hot.</li> <li>8. Compressor motor has a winding shorted.</li> </ol>	<ol style="list-style-type: none"> <li>1. Check wiring diagram. Check for added fan motors, pumps, etc., connected to wrong side of protector.</li> <li>2. Determine reason and correct.</li> <li>3. Check current, replace protector.</li> <li>4. Determine reason and replace.</li> <li>5. Check ventilation, restrictions in cooling medium, restrictions in refrigeration system.</li> <li>6. Check for possibility of misapplication. Use stronger unit.</li> <li>7. Check refrigerant charge (fix leak), add if necessary.</li> <li>8. Replace compressor.</li> </ol>
<b>E</b> Unit runs OK, but short cycles on	<ol style="list-style-type: none"> <li>1. Overload protector.</li> <li>2. Thermostat.</li> <li>3. High pressure cut-out due to: <ol style="list-style-type: none"> <li>a. Insufficient air.</li> <li>b. Overcharge.</li> <li>c. Air in system.</li> </ol> </li> <li>4. Low pressure cut-out due to: <ol style="list-style-type: none"> <li>a. Liquid line solenoid leaking.</li> <li>b. Compressor valve leak.</li> <li>c. Undercharge.</li> <li>d. Restriction in expansion device.</li> </ol> </li> </ol>	<ol style="list-style-type: none"> <li>1. See D. above.</li> <li>2. Differential set too close - widen.</li> <li>3a. Check air or water supply to condenser - correct.</li> <li>3b. Reduce refrigerant charge.</li> <li>3c. Purge.</li> <li>4a. Replace.</li> <li>4b. Replace.</li> <li>4c. Fix leak, add refrigerant.</li> <li>4d. Replace device.</li> </ol>

WARNING: ELECTRICAL POWER MUST BE DISCONNECTED WHEN TERMINAL PROTECTIVE COVER NOT IN PLACE TO PROTECT AGAINST ELECTROCUTION OR VENTED TERMINAL.

# CFC & REFRIGERATION BASICS

## Trouble Shooting and Service Chart ... Continued

COMPLAINT	POSSIBLE CAUSE	REPAIR
<b>F</b> Unit operates long or continuously	<ol style="list-style-type: none"> <li>1. Shortage of refrigerant.</li> <li>2. Control contacts stuck or frozen closed.</li> <li>3. Refrigerated or air conditioned space has excessive load or poor insulation.</li> <li>4. System inadequate to handle load.</li> <li>5. Evaporator coil iced.</li> <li>6. Restriction in refrigeration system.</li> <li>7. Dirty condenser.</li> <li>8. Filter dirty.</li> </ol>	<ol style="list-style-type: none"> <li>1. Fix leak, add charge.</li> <li>2. Clean contacts or replace control.</li> <li>3. Determine fault and correct.</li> <li>4. Replace with larger system.</li> <li>5. Defrost.</li> <li>6. Determine location and remove.</li> <li>7. Clean condenser.</li> <li>8. Clean or replace.</li> </ol>
<b>G</b> Start capacitor open, shorted, or blown	<ol style="list-style-type: none"> <li>1. Relay contacts not operating properly.</li> <li>2. Prolonged operation on start cycle due to:               <ol style="list-style-type: none"> <li>a. Low voltage to unit.</li> <li>b. Improper relay.</li> <li>c. Starting load too high.</li> </ol> </li> <li>3. Excessive short cycling.</li> <li>4. Improper capacitor.</li> </ol>	<ol style="list-style-type: none"> <li>1. Clean contacts or replace relay if necessary.</li> <li>2a. Determine reason and correct.</li> <li>2b. Replace.</li> <li>2c. Correct by using pump down arrangement if necessary.</li> <li>3. Determine reason for short cycling (E above) and correct.</li> <li>4. Determine correct size &amp; replace.</li> </ol>
<b>H</b> Run capacitor open, shorted, or blown	<ol style="list-style-type: none"> <li>1. Improper capacitor.</li> <li>2. Excessively high line voltage (110% of rated-max.).</li> </ol>	<ol style="list-style-type: none"> <li>1. Determine correct size and replace.</li> <li>2. Determine reason and correct.</li> </ol>
<b>I</b> Relay defective or burned out	<ol style="list-style-type: none"> <li>1. Incorrect relay.</li> <li>2. Incorrect mounting angle.</li> <li>3. Line voltage too high or too low.</li> <li>4. Excessive short cycling.</li> <li>5. Relay being influenced by loose vibrating mounting.</li> <li>6. Incorrect run capacitor.</li> </ol>	<ol style="list-style-type: none"> <li>1. Check and replace.</li> <li>2. Remount relay in correct position.</li> <li>3. Determine reason and correct.</li> <li>4. Determine reason (See E above) and correct.</li> <li>5. Remount rigidly.</li> <li>6. Replace with proper capacitor.</li> </ol>
<b>J</b> Space temperature too high	<ol style="list-style-type: none"> <li>1. Control setting too high.</li> <li>2. Expansion valve too small.</li> <li>3. Cooling coils too small.</li> <li>4. Inadequate air circulation.</li> </ol>	<ol style="list-style-type: none"> <li>1. Reset control.</li> <li>2. Use larger valve.</li> <li>3. Add surface or replace.</li> <li>4. Improve air movement.</li> </ol>
<b>K</b> Suction line frosted or sweating	<ol style="list-style-type: none"> <li>1. Expansion valve passing excess refrigerant or is oversized.</li> <li>2. Expansion valve stuck open.</li> <li>3. Evaporator fan not running.</li> <li>4. Overcharge of refrigerant.</li> </ol>	<ol style="list-style-type: none"> <li>1. Readjust valve or replace with smaller valve.</li> <li>2. Clean valve of foreign particles, replace if necessary.</li> <li>3. Determine reason and correct.</li> <li>4. Correct charge.</li> </ol>
<b>L</b> Liquid line frosted or sweating	<ol style="list-style-type: none"> <li>1. Restriction in dehydrator or strainer.</li> <li>2. Liquid shut-off (king valve) partially closed.</li> </ol>	<ol style="list-style-type: none"> <li>1. Replace part.</li> <li>2. Open valve fully.</li> </ol>
<b>M</b> Unit noisy	<ol style="list-style-type: none"> <li>1. Loose parts or mountings.</li> <li>2. Tubing rattle.</li> <li>3. Bent fan blade causing vibration.</li> <li>4. Fan motor bearings worn.</li> </ol>	<ol style="list-style-type: none"> <li>1. Find and tighten.</li> <li>2. Reform to be free of contact.</li> <li>3. Replace blade.</li> <li>4. Replace motor.</li> </ol>

WARNING: ELECTRICAL POWER MUST BE DISCONNECTED WHEN TERMINAL PROTECTIVE COVER NOT IN PLACE TO PROTECT AGAINST ELECTROCUTION OR VENTED TERMINAL.

## CAPILLARY TUBE REPLACEMENT INSTRUCTIONS

### Upright GDM/T-Series Equipment

#### TOOLS REQUIRED

Drill  
Hole Saw  
½" Copper Coupling  
Two ½" 90° Copper Elbow  
Torch  
Heat Shield  
Tube Cutter  
Foam Insulation  
Cap Tube Suction Line Assembly  
(Supplied)  
Liquid Line Filter Drier (Supplied)  
Cover (Supplied)  
Wire Back Guards  
(GDM/T-23 Freezer  
Model only require ordering part  
number 8729777)

#### STEP 1

Inspect supplied cap tube suction line assembly. The kit should include one ½" suction line, cap tube, accumulator section (shipped loose).

#### **NOTE:**

You may have to secure the cap tube to the suction line with the supplied foil tape. Be sure to use all of the supplied cap tube. The excess cap tube should be coiled up and left inside the evaporator section.

#### STEP 2

Remove the power supply to the cabinet.

#### STEP 3

Recover the refrigerant from the unit.

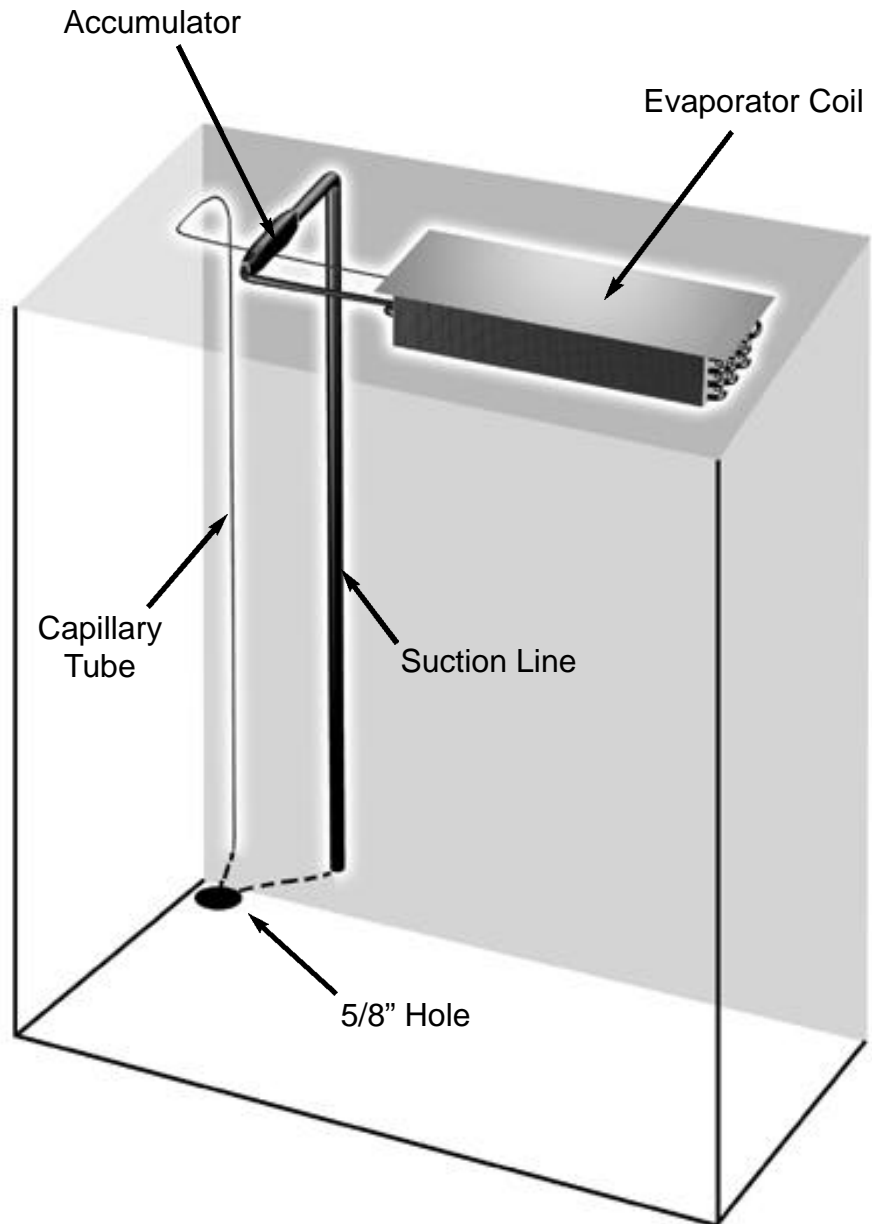

Figure 1.

# CAPILLARY TUBE REPLACEMENT INSTRUCTIONS

## Upright GDM/T-Series Equipment Continued.....

### STEP 4

Remove all of the shelves.

### STEP 5

Remove the wire back guards on the back wall of the cabinet.

### NOTE:

These are in freezers models only.

### STEP 6

Disconnect the evaporator drain line.

### STEP 7

Drop down the evaporator housing by removing the 1/4" screws that hold it in place. Remove the temperature control wires and allow the assembly to hang down on the right side of cabinet.

### STEP 8

Locate the two 1/4" screws that hold the left side evaporator up and remove them.

### STEP 9

Un-solder the capillary tube from the evaporator. NOTE: The use of a heat shield is recommended.

### STEP 10

Un-solder the accumulator from the Evaporator and the suction line. After the old suction lines cools down you can crimp it closed.

### NOTE:

The use of a heat shield is recommended.

### STEP 11

Drill a 5/8" hole in the floor as close to the Left rear corner of the cabinet as possible. See Figure 1.

### STEP 12

Place the cap tube suction line assembly in the cabinet.

### STEP 13

Take the accumulator and hold it up inside the cabinet and mark the suction line where it needs to be cut. You may have to cut some of the line coming from the accumulator.

### STEP 14

Remove the suction line and cut it. Using a 90° copper elbow, join and solder the suction line and the accumulator.

### NOTE:

This step is easier to preform outside of the cabinet. See Figure 2.

### STEP 15

Insulate the suction line where the line come out under the cabinet.

### STEP 16

Place the cap tube suction line with the accumulator inside the cabinet.

### STEP 17

Solder the capillary tube in to the evaporator as well as the accumulator to the evaporator.

### STEP 18

Solder the suction line down where the suction line meets with the below compressor pull out.

### STEP 19

Solder the cap tube to the into the copper line that goes into the outlet of liquid line filter drier.

### STEP 20

Pressurize the system using nitrogen to leak check. If a leak is found, repair the leak and repeat this step.

### STEP 21

Pull a vacuum on the unit.

### NOTE:

The use of a micron gauge is recommended.

### STEP 22

Reassemble the evaporator section.

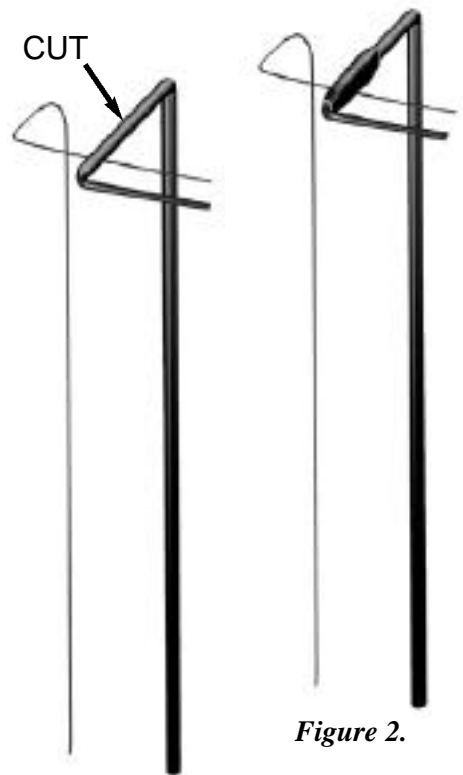

Figure 2.

### STEP 23

Check the cabinet operation.

### STEP 24

Place the cover over the new cap tube suction line assembly and secure it to the back wall using several small sheet metal screws or pop rivets.

### STEP 25

Place the back guards back in the unit.

### STEP 26

Finish reassembling the cabinet.

# REFRIGERATION TROUBLESHOOTING CHART

## Refrigerator

### REFRIGERATION TROUBLESHOOTING CHART (REFRIGERATOR)

**PROBLEM** Cabinet is running warm.

1. Are lights and evaporator fan working?

**NO** Check to make sure cabinet is plugged in, check to make sure circuit breaker is not tripped, check to see if temperature control is set on #5.

**YES** Remove the grill covering the condensing unit.

2. Is the condenser coil (looks like a car radiator) clean? If not clean this with a brush and either a vacuum or condensed air. Wait and let the cabinet run with a clean coil and see if that solves problem.  
(CONDENSER COILS SHOULD BE CLEANED MONTHLY)

3. Can you here the compressor and condenser fan motor running?

**NO** Check the voltage at the compressor receptacle. It should be 115 volts  $\pm 10\%$ . Using a remote reading thermometer, check the evaporator coil temperature. If the temperature control is set on #5 and the coil temperature is above 40 degrees the control should be closed calling for the compressor to run. If the coil temperature is above 40 degrees and the temperature control does not close.

- A. remove the temperature control from the evaporator housing and either calibrate or replace control.
- **Verify on your wiring diagram but most models have a pink wire that is connected to the power cord black wire in the electrical box. This feeds one side of the temperature control and the other pink wire is connected to the other side of the control to bring power to the compressor receptacle when the switch closes on a call for refrigeration.**

**YES** Is the evaporator coil frozen? Check to see if temperature control is operating correctly. If the evaporator coil is not iced up and the compressor and condenser fan is running please install piercing valves on both the suction and discharge process tubes.

1. If pressures are equalized (high suction pressure, low head pressure) and compressor is running low amp draw, compressor has bad valves replace compressor.
2. If you have low suction pressure and low discharge pressure first check to make sure there are no kinks in the compressor pullout or the suction line after doing this you have a few options.
  - A. Add a few ounces of refrigerant and see what happens.
  - B. Recover charge and weigh in correct amount of refrigerant.

## **REFRIGERATION TROUBLESHOOTING CHART**

### **Refrigerator ...continued**

If the pressures rose and the cabinet began to function correctly, the cabinet was low on charge. This means that there is a leak in the refrigeration system that must be located. A technician can raise system pressure up to 200 psi with nitrogen to aid in the leak search. (Remember that the foam insulation within the cabinet will make a leak detector sniffer type react.)

**AFTER LEAK IS LOCATED IT IS VERY IMPORTANT THAT THE SYSTEM DRIER IS CHANGED AND THAT A 200 MICRON VACUUM IS PULLED THROUGH BOTH THE HIGH AND LOW SIDE ACCESS FITTINGS.**

When leak is found recover refrigerant, at this time the technician may want to remove piercing valves and solder on access valves to pull vacuum and recharge system. (After charging system both service valves should removed from the system.)

If the head pressure rises but falls right back down after you stop adding gas and the suction pressure stays low there may be a restriction in the system. Recover the charge and cut out the drier also cut about 1" off of the capillary tube. Circulate nitrogen through the system to clear any restrictions in the evaporator. Evacuate the system and recharge.

If the problem still exists capillary tube may need to be replaced.



## REFRIGERATION TROUBLESHOOTING CHART

### Freezer

## REFRIGERATION TROUBLESHOOTING CHART (FREEZER)

**PROBLEM** Cabinet is running warm.

Can you hear the compressor running?

**NO** If nothing is running and cabinet is warm check to make sure cabinet is plugged in and then check circuit breaker. GDM cabinet lights will not come on until cabinet reaches 20 degrees but on T series cabinets lights will work when you open the door at any temperature. All freezers have a fan delay that will not allow the evaporator fans to start before the coil gets to 15 degrees.

Remove the grill covering the condensing unit. Check the defrost timer to see if cabinet is in defrost. Do not turn dial on defrost timer, take a pencil and mark a spot on the outer dial and watch this to see if timer is working. This should take no more than 10 minutes to verify. While waiting, look to see if the condenser coil (looks like a car radiator) is clean. If coil is dirty clean with a brush and a vacuum or compressed air. (CONDENSER COILS SHOULD BE CLEANED MONTHLY)

If cabinet is not in defrost and the compressor and condenser fan motor is not running, unplug the condensing unit and check the voltage at the compressor receptacle. The voltage should be within 10% on a 115 volt compressor and within 5% on a 208 /230 volt compressor.

Any voltage less than that unplug cabinet and remove the temperature control from the evaporator housing and check out control. Control could be stuck open or be pitted due to low voltage or short cycling. *Refer to Temperature Control Change-Out Instructions, page 39-41.*

- **There is a wiring diagram on the back of the electrical box cover plate. Use this to help you troubleshoot.**

**YES** The compressor is running and cabinet is warm. Does the evaporator coil have an ice build up on it? If so follow above directions on how to verify if timer is advancing. If it is manually turn timer and put freezer into defrost to check defrost heaters.

After ice build up is gone restart cabinet if box starts to freeze properly cabinet may not have enough defrost times. Set timer for 4 defrosts a day. You may also want to check out defrost heater voltage and amperage at this time to verify that there is not a heater or voltage problem.

If the compressor is running and there is no ice build up on the evaporator coil, install gauges on the suction and discharge side of the system and check the system operating pressures.

## **REFRIGERATION TROUBLESHOOTING CHART**

### **Freezer ...Continued**

1. If compressor is running and you have a low amp draw with a high suction pressure and a low head pressure your compressor has bad valves **replace compressor**.
2. If you have a low suction pressure and a low head pressure you may have one of a few different things happening with your system.
  - A. Kinks in the suction line or compressor pullout.
    1. Check for kinks and repair tubing if needed.
  - B. CRO valve not functioning correctly.
    1. Install a line tap in suction line to verify pressure upstream of valve, replace valve if needed.
  - C. Evaporator or accumulator may be logged with oil.
    1. Disconnect termination switch from timer and run system through an extended defrost cycle to warm oil and get it to return to the compressor after putting back in freeze cycle.
    2. Allow evaporator to warm up and remove capillary tube from evaporator then blow nitrogen through evaporator. You may also want to poke a hole in the accumulator with a scratch awl to add in the oil removal.
  - D. You may also have a system that is low on refrigerant charge or have a capillary tube or drier that is restricting refrigerant flow.
    1. Add a few ounces of refrigerant to system.
    2. Recover the charge and weigh in the correct amount of refrigerant.

**With either of these options used if the pressures rise and the cabinet begins to function correctly we know that the cabinet was low on charge. This means that there is a leak in the refrigeration system that now must be located. A technician can raise the system pressure up to 200 psi with nitrogen to aid in the leak search. Remember that the foam itself will make a leak detector (sniffer type) react.**

**AFTER LEAK IS LOCATED IT IS VERY IMPORTANT THAT THE SYSTEM DRIER IS CHANGED AND THAT A 200 MICRON VACUUM IS PULLED THROUGH BOTH THE HIGH AND LOW SIDE ACCESS FITTINGS.**

When leak is located recover refrigerant, at this time the technician may want to remove any line taps they might have installed and solder on access fittings to pull the vacuum and recharge the system. (After charging the system both of the access valves must be removed from the system.)

If the head pressure falls right back down after you stop adding refrigerant and the suction pressure stays low there may be a restriction in the system Recover refrigerant and cut out the drier along with about 1 " of the capillary tube. Circulate nitrogen through the system to clear any restrictions in the evaporator. Evacuate the system and recharge.

If the problem still exists the capillary tube may need to be replaced.

# **CAPILLARY TUBE REPLACEMENT INSTRUCTIONS**

## **Refrigerators and Freezers**

Depending on what model; cabinet you may have you will always have a couple of options when it comes to replacing the capillary tube.

### **REFRIGERATORS**

Some model cabinets for example GDM slide door cabinets have capillary tube/suction line assembly behind the rear center shelf standard. These are easy to access and change. On refrigerator cabinets that do not have a rear center shelf standard, here are you options.

1. You can run a new suction line/capillary tube assembly up the rear of the cabinet and drill a hole above the evaporator housing to bring the tubing inside the cabinet to pipe back to the evaporator.
2. Cut the suction line a couple of inches below where it enters the cabinet also cut it a couple of inches from the evaporator coil. Install new capillary tube inside of the existing suction line. Now use Tee's to reconnect suction line while feeding capillary tube out of the other side of the Tee.

### **FREEZERS**

The above methods of replacing capillary tubes on refrigerators can also be used on freezers. There is also one other option that is used only on freezers.

1. Drill a hole in the rear left hand corner through the floor on the inside of the cabinet, run the new assembly up the rear left hand corner and reconnect to the evaporator. After re-piping cover the assembly up with a corner cover that can be ordered from True's parts department.

Remember that P.O.E. oil is now being used and it is very hygroscopic. You should only have the system open for no more than 15 minutes and then replace drier and pull a 200-micron vacuum through both sides of the system.



## FIELD TROUBLESHOOTING

### IF THE COMPRESSOR WILL NOT RUN

1. If there is no voltage at the compressor terminals, follow the wiring diagram and check back from compressor to the power supply to find where the circuit is interrupted.
2. If power is available at the compressor terminals, and the compressor does not run, check the voltage at the compressor terminals while attempting to start the compressor.

If voltage at the compressor terminals is below 90% of the nameplate voltage, it is possible the motor may not develop sufficient torque to start. Check to determine if wire sizes are adequate, electrical connections are loose, the circuit is overloaded, or if the power supply is inadequate.

3. On single phase compressors, a defective capacitor or relay may prevent the compressor starting. If the compressor attempts to start but is unable to do so, or if there is a humming sound, check the relay to see if the relay contacts are damaged or fused. The relay points should be closed during the initial starting cycle, but should open as the compressor comes up to speed.

Remove the wires from the starting relay and capacitors. Use a high voltage ohmmeter to check for continuity throughout the relay coil. Replace the relay if there is not continuity. Use an ohmmeter to check across the relay contacts. Potential relay contacts are normally closed when the relay is not energized, current relay contacts are normally open. If either gives an incorrect reading, replace the relay.

Any capacitor found to be bulging, leaking, or damaged should be replaced.

Make sure capacitors are discharged before checking. Check for continuity between each capacitor terminal and the case. Continuity indicates a short, and the capacitor should be replaced.

Substitute a "known to be good" start capacitor if available. If compressor then starts and runs properly, replace the original start capacitor.

If a capacitor tester is not available, an ohmmeter may be used to check run and start capacitors for shorts or open circuits. Use an ohmmeter set to its highest resistance scale, and connect prods to capacitor terminals.

a) With a good capacitor, the indicator should first move zero, and then gradually increase to infinity.  
b) If there is no movement of the ohmmeter indicator, an open circuit is indicated.

c) If the ohmmeter indicator moves to zero, and remains there or on a low resistance reading, a short circuit is indicated. Defective capacitors should be replaced.

4. If the correct voltage is available at the compressor terminals, and no current is drawn, remove all wires from the terminals and check for continuity through the motor windings. On single phase motor compressors, check for continuity from terminals C to R, and C to S. On compressors with line break inherent protectors, an open overload protector can cause a lack of continuity. If the compressor is warm, wait one hour for the compressor to cool and recheck. If continuity cannot be established through all motor windings, the compressor should be replaced.

Check the motor for ground by means of a continuity check between the

common terminal and the compressor shell. If there is a ground, replace the compressor.

5. If the compressor has an external protector, check for continuity through the protector or protectors.

All external inherent protectors on compressors can be replaced in the field.

### IF THE MOTOR COMPRESSOR STARTS BUT TRIPS REPEATEDLY ON THE OVERLOAD PROTECTOR

1. Check the compressor suction and discharge pressures while the compressor is operating. Be sure the pressures are within the limitations of the compressor. If pressures are excessive it may be necessary to clean the condenser, purge air from the system, replace crankcase pressure regulating valve.

An excessively low suction pressure may indicate a loss of charge.

On units with no service gauge parts where pressures can be checked, check condenser to be sure it is clean and fan is running. Excessive temperatures on suction and discharge line may also indicate abnormal operating conditions.

2. Check the line voltage at the motor terminals while the compressor is operating. The voltage should be within 10% of the nameplate voltage rating. If outside those limits, the voltage supply must be brought within the proper range, or a motor compressor with different electrical characteristics must be used.

## FIELD TROUBLESHOOTING

3. Check the amperage drawn while the compressor is operating. Under normal operating conditions, the amperage drawn will seldom exceed 110% of the nameplate amperage. High amperage can be caused by low damage, defective running capacitors, or a defective starting relay.
4. If all operating conditions are normal, the voltage supply at the compressor terminals balanced and within limits, the compressor crankcase temperature within normal limits, and the amperage drawn within the specified range, the motor protector may be defective, and should be replaced.

If the operating conditions are normal and the compressor is running excessively hot for no observable reason, or if the amperage drawn is above the normal range and sufficient to repeatedly trip the protector, the compressor has internal damage and should be replaced.

### IF THE COMPRESSOR RUNS BUT WILL NOT REFRIGERATE

1. Check the refrigerant charge. Check the evaporator surface to determine if it is evenly cold throughout, or if partially starved. A lack of charge may be indicated by light, fluffy frost at the evaporator inlet. Add refrigerant if necessary.
2. Check the compressor suction pressure. An abnormally low pressure may indicate a loss of refrigerant charge, a malfunctioning capillary tube, a lack of evaporator capacity possibly due to icing or low air flow, or a restriction in the system.

Often a restriction in a drier or strainer can be identified by frost or a decrease in temperature across the restriction due to the pressure drop in the line. This will be true only if liquid refrigerant is in the line at the restricted point, since any temperature change due to restriction would be caused by the flashing of liquid into

vapor as the pressure changes.

Any abnormal restriction in the system must be corrected.

3. Check the compressor discharge pressure. An abnormally high discharge pressure can cause a loss of capacity, and can be caused by a dirty condenser, a malfunctioning condenser fan, or air in the system.
4. If the suction pressure is high, and the evaporator and condenser are functioning normally, check the compressor amperage draw. An amperage draw near or above the nameplate rating indicates normal compressor or unit may have damaged valves.

An amperage draw considerably below the nameplate rating may indicate a broken suction reed or broken connecting rod in the compressor.

### DIAGNOSIS AND REPLACEMENT OF FREEZER CABINET COMPONENTS

1. Defrost Time Clock
  - A. Check timer motor to be sure it runs.
  - B. Check contacts on the defrost timer.
  - C. Check solenoid windings for continuity to ensure contact switching.
  - D. Check to be sure defrost actuator pins are in proper position.
  - E. Check all wires in the timer for tightness to terminals and broken wires.
2. Defrost Control On The Evaporator Drain Pan
  - A. If the defrost time is always 35 minutes (or whatever duration the elapsed time adjustment is set at) and the fan motors do not delay after a defrost cycle and it has been determined that the solenoid in the defrost clock is functioning, change the defrost control in the evaporator compartment in the top of the freezer. This control is attached to the evaporator drain pan.

3. Coil Defrost Heater
  - A. Lower the evaporator cover. Disconnect the coil heater by removing the wire nuts at the point where the heater joins the electrical circuit of the freezer in the evaporator compartment. Check heater for continuity with an ohmmeter. If the heater is defective, cut the bale wires holding the heater to the coil and remove the heater. Replace with a new heater using bale wires provided.
4. Drain Tube Heater
  - A. Lower the evaporator cover. Disconnect the drain tube heater by removing the wire nuts at the point where the heater joins the electrical circuit of the freezer in the evaporator compartment. Check the drain tube heater with an ohmmeter.
  - B. If the drain tube heater is defective, disconnect the drain tube from the rigid plastic drain, bend the tabs that hold the evaporator drain pan to the evaporator cover and raise the drain pan so that the flexible heater is visible, pull heater out of the plastic drain tube and replace. Connect heater to the electrical circuit in the evaporator compartment.



## FIELD TROUBLESHOOTING

---

### 5. Cabinet Temperature Control

- A. Remove the two screws on the right side of the evaporator housing that holds the control mounting plate. Reach behind the evaporator housing on the control side of the cabinet and pull the control bulb out of the receptacle in the roof of the cabinet. Disconnect the wires from the control. Check control for continuity, replace if defective.

### 6. Evaporator Fan Motor

- A. Remove fan blade guard from the evaporator housing. Remove the blade. Remove screws holding the evaporator motor. Disconnect wires by removing wire nuts.

### 7. C.R.O. Valve

- A. Remove the refrigerant from the system to an equalized 0 pounds pressure. Remove securing strap holding the valve to the condensing unit base. Replace the valve. Evacuate the system to 100 microns and recharge the system.

### 8. Fan Door Switch (and lights on "T" Models)

- A. Pull switch downward out of the square hole overriding the holding tabs. Remove wires and replace the switch.

### ***FREEZER PERIMETER HEATER WIRE REPLACEMENT***

1. Disconnect the power supply, unload contents of cabinet and lay cabinet on its back.
2. Remove the lower louvered grill. Remove the stainless steel skirt around the louvered grill.
3. Remove the sign or the louver section above the door(s).
4. Remove hinges and door(s).
5. Drill out pop rivet on right top corner of plastic and stainless steel mullion trim. Remove horizontal top stainless steel strip by sliding it to the right on the tracks in the plastic. Be sure to raise the corner of the plastic trim where the pop rivet was removed so that the stainless trim slides beneath it. Drill out the two pop rivets in the top plastic trim which was hidden by the horizontal piece of stainless trim.
6. Remove left and right vertical stainless steel trim pieces by sliding them out of the plastic trim. Be sure to raise the top horizontal plastic trim piece so that the stainless trim passes underneath it toward the top of the cabinet.

7. Drill out the pop rivet that was hidden by the stainless steel trim in the lower right corner of the vertical plastic piece. Raise this corner of the vertical plastic piece so that the lower vertical stainless trim slides beneath it for removal.
8. Remove three (3) screws on each side of the center mullion and raise mullion out of the cabinet and slide the stainless trim past the top of the cabinet.
9. Disconnect heater wires in the junction box. Remove heater wire loop by unhooking at the corners where it is retained by the plastic trim pieces.
10. Replace inoperative heater wire loop, being sure to hook under the corners of the plastic trim as observed during disassembly.
11. Reverse assembly sequence to replace trim. Use the four (4) small sheet metal screws furnished with the heater wire in the same sequence as the pop rivets were removed.
12. Attach the heater wires to the power supply in the junction box. Replace all other assemblies in reverse sequence in which they were removed.

## **TROUBLESHOOTING FLUORESCENT LIGHTING CIRCUITS** —

### **Electromagnetic Rapid Start, Instant Start Electronic, and Preheat Fluorescent Light Circuits**

#### **WARNING:**

**A qualified service technician must be used to preform these tests using extreme care because of the risk of electrocution if tests are not preformed correctly.**

There are different types of lighting systems being used in True cabinets, so there will be different types of troubleshooting techniques that need to be used. The one common aspect in all of the lighting circuits is that the bulbs being used must be the same as the bulbs that were originally installed in the cabinet.

**To test ballast determine which lighting system you are working on and follow steps below.**

**Electromagnetic rapid start fluorescent light circuit** – There are three different voltage tests.

Incoming or ballast supply voltage- Test at black and white wires going to ballast. You should read approximately 118 volts.

Filament voltage- Tested between red to red wires or blue to blue wires. Depending on which ballast you have you should get a reading between 2 and 5 volts with the bulbs out. Please call technical service with the ballast number to get the correct voltage reading.

High voltage- Test between either red wire and either blue wire. Again depending on which ballast you are checking the voltage can range between 205 and 310 volts with the bulbs out. Please call technical service with the ballast number for the correct voltage reading.

**Instant start electronic fluorescent light circuit** - (**Note:** A high impedance meter is required for testing this ballast.). There are two different voltages to test.

Incoming or ballast supply voltage - Test at the black and white wires going to the ballast. You should read approximately 118 volts.

High voltage - Test between the red wires and anyone of the blue wires with the bulbs out. You should read approximately 600 volts (+ or - 10%).

**Preheat fluorescent light circuit** – Test voltage between pins on each end of the lamp. You should get approximately 118 volts from one pin on one end to one pin on the other. You can also check for continuity between the other pins on either end to the starter base. (To do this test make sure there is no voltage to the circuit and remove the starter from the base.) If both are ok change the bulb first and then change the starter.

**FOR ANY INFORMATION OR HELP DIAGNOSING BALLAST PROBLEMS PLEASE CALL.**

TRUE MANUFACTURING TECHNICAL SERVICE

1-800-325-6152

Revised 9-24-02 SB

# GDM & T SERIES COOLERS IDL CONNECTOR

## 2 Door IDL Cooler Wiring

and Y cord on 3 door cabinet

- Blue #1 on R.S. or 24K ballast — 1
- Yellow #1 on R.S. or Red on 24K ballast — 2
- Blue #2 on R.S. or Blue #1 on 24K ballast — 3
- Yellow #2 on R.S. or Red on 24K ballast — 4
- Red #1 on R.S. or Blue #2 on 24K ballast — 6
- Yellow #2 on R.S. or Red on 24K ballast — 7
- Red #2 on R.S. or Blue #2 on 24K ballast — 8
- Yellow #1 on R.S. or Red on 24K ballast — 9

- Pin 1 - Pigtail black to door black (upper lamp holder)
- Pin 2 - Pigtail white to door white (lower lamp holder)
- Pin 3 - Pigtail red to door red (heaters)
- Pin 4 - Pigtail green to door black (upper lamp holder)
- Pin 5 - Pigtail brown to door white (lower lamp holder)
- Pin 7 - Pigtail blue to door blue (heaters)

- °1     °4     °7     Female plug for door cord.
- °2     °5     °8
- °3     °6     °9

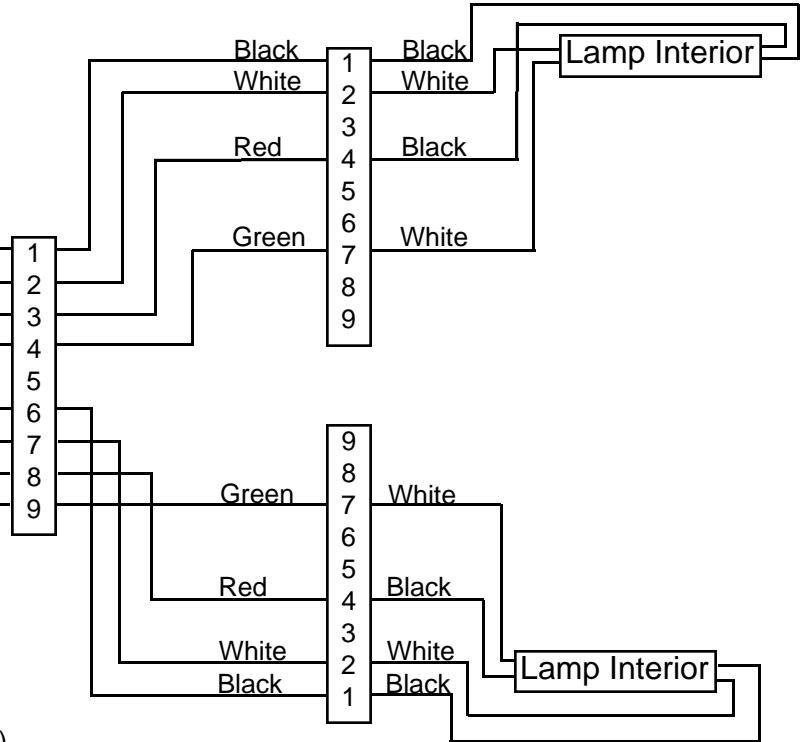

## 2 Door IDL Freezer Wiring

and Y cord on 3 door cabinet

- Yellow on VHO or Red on 24K ballast — 1
- Blue #1 on VHO or 24K ballast — 2
- Black from Org/Blk in harness — 3
- Yellow on VHO or Red on 24K ballast — 4
- Blue #2 on VHO or Blue #1 from 24K ballast — 5
- Red #1 on VHO or Blue #2 on 24K ballast — 6
- White from neutral Bundle — 7
- Red #2 on VHO or Blue #2 on 24K ballast — 9

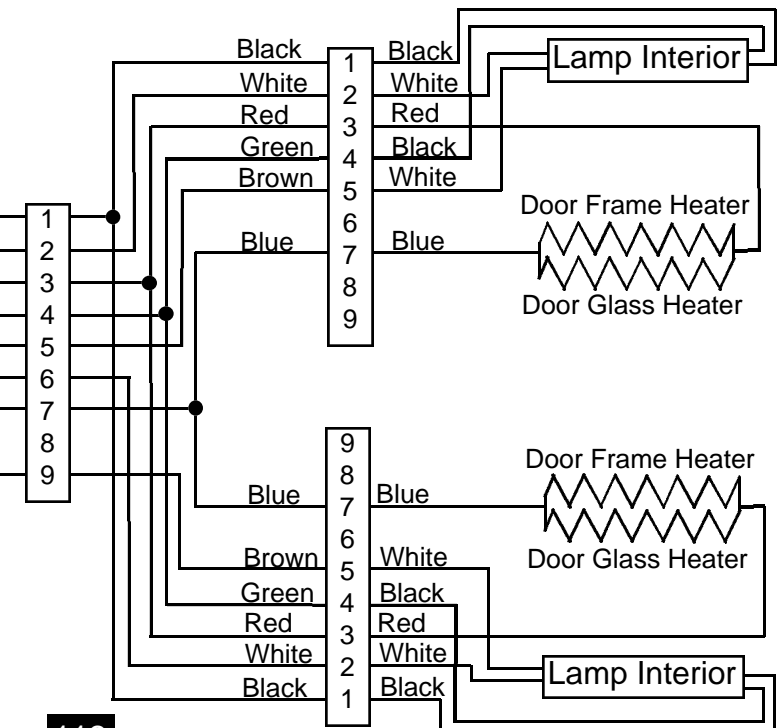



# **Notes**

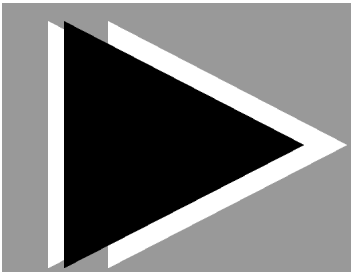

***EQUIPMENT  
CARE AND  
CLEANING***

## **Cleaning Your Cabinet**

*Cleaning Exterior, Vinyl Clad, Galvanized, and Aluminum interior of cabinet:*

**True recommends the use of soap and warm water to clean these parts of the cabinet.**

***Warning: Use of abrasive or chlorine based cleaners will damage your cabinet.***



***STAINLESS STEEL EQUIPMENT CARE AND CLEANING***  
***NAFEM - North American Association of Food Equipment Manufacturers***

# **STAINLESS STEEL EQUIPMENT CARE AND CLEANING**

**NAFEM**

**North American Association of Food  
Equipment Manufacturers**



## So, what does all this mean?

At this very moment you're gritting your teeth and saying,

"Well, what am I supposed to do now? The only way to get that crusted lasagna off my stainless steel is to use some kind of scouring pad, and I certainly need to use a cleaner, and the water in this town is hard enough to cut diamonds."

## Don't Despair!

Here are a few steps that can help prevent stainless steel rust.

### 1. Use the proper tools

When cleaning your stainless steel products, take care to use non-abrasive tools. Soft cloths and plastic scouring pads will not harm the steel's passive layer. Stainless steel pads can also be used but the scrubbing motion must be in the direction of the manufacturers' polishing marks. (Step 2 tells you how to find the polishing marks).

### 2. Clean with the polish lines

Some stainless steels come with visible polishing lines or "grain." When visible lines are present, you should always scrub in a motion that is parallel to them. When the grain cannot be seen, play it safe and use a soft cloth or plastic scouring pad.

### 3. Use alkaline, alkaline chlorinated or non-chloride containing cleaners

While many traditional cleaners are loaded with chlorides, the industry is providing an ever increasing choice of non-chloride cleaners. If you are not sure of your cleaner's chloride content contact your cleaner supplier. If they tell you that

your present cleaner contains chlorides, ask if they have an alternative. They probably will. Also, avoid cleaners containing quaternary salts as they also can attack stainless steel and cause pitting and rusting.

### 4. Treat your water

Though this is not always practical, softening hard water can do much to reduce deposits. There are certain filters that can be installed to remove distasteful and corrosive elements. Salts in a properly maintained water softener are your friend. If you are not sure of the proper water treatment, call a treatment specialist.

### 5. Keep your food equipment clean

Use alkaline, alkaline chlorinated or non-chloride cleaners at recommended strength. Clean frequently to avoid build-up of hard, stubborn stains. If you boil water in your stainless steel equipment, remember the single most likely cause of damage is chlorides in the water. Heating cleaners that contain chlorides has a similar effect.

## DON'T USE

Steel Pads  
Wire Brushes  
Scraper

## **STAINLESS STEEL EQUIPMENT CARE AND CLEANING**

**NAFEM - North American Association of Food Equipment Manufacturers**

### **6. Rinse, Rinse, Rinse**

If chlorinated cleaners are used you must rinse, rinse, rinse and wipe dry immediately. The sooner you wipe off standing water, especially when it contains cleaning agents, the better. After wiping the equipment down, allow it to air dry for the oxygen helps maintain the stainless steels' passivity film.

**7. Never use hydrochloric acid (muriatic acid) on stainless steel**

**8. Regularly restore / passivate stainless steel**

### **Recommended cleaners for specific situations**

<b>Job</b>	<b>Cleaning Agent</b>	<b>Comments</b>
Routine cleaning	Soap, ammonia, detergent Medallion	Apply with cloth or sponge
Fingerprints & smears	Arcal 20, Lac-O-Nu Ecoshine	Provides barrier film
Stubborn stains & discoloration	Cameo, Talc, Zud First Impression	Rub in direction of polish lines
Grease & fatty acids, blood, burnt-on foods	Easy-off, DeGrease It Oven Aid	Excellent removal on all finishes
Grease & oil	Any good commercial detergent	Apply with sponge or cloth
Restoration/ Passivation	Benefit, Super Sheen	



## **What does Corroded Stainless Steel Look Like?**

### **Passive Film Breakdown**

If the passive film of your stainless steel has been broken, your equipment will begin the long walk down the dark road of corrosion. At it's end; rust.

The first signs are on the microscopic level. If you were to look at them under a microscope or through a magnifying glass, you would see small pits and cracks staring back at you. Given time, these pits and cracks will grow and deepen while all the time exuding unsightly, red-orange rust.

More severe and visible cracking can also take place.

## **Contrary to popular belief, Stainless Steels ARE susceptible to rusting**

Corrosion on metals is everywhere. We recognize it quickly on iron and steel as unsightly yellow / orange rust. Such metals are called "active" because they actively corrode in the natural environment.

Stainless steels are passive metals because they contain other metals, like chromium and nickel. 400 series stainless steels contain chromium while 300 series contain both chromium and nickel.

Metals are crystalline solids made up in atom arrangements like tinker toys. With 12-30% chromium, an invisible passive film covers the steels surface acting as a shield against corrosion. The metal becomes "passive" toward corrosion.

**As long as the film is intact; not broken or contaminated, the metal is passive and stainless.**



## **Enemies of Stainless Steel**

There are three basic things which can break down your stainless steels passivity layer and allow corrosion to rear its ugly head.

### **1. Mechanical abrasion**

### **2. Deposits & Water**

### **3. Chlorides**

**Mechanical abrasion** means those things that will scratch the surface. Steel pads, wire brushes, and scraper are prime examples.

**Water** comes out of our tap in varying degrees of hardness. Depending on what part of the country you live in, you may have hard or soft water. Hard water may leave spots. Also, when heated, hard water leaves deposits behind that if left to sit, will break down the passive layer and rust your stainless steel. Other deposits from food preparation and service must be properly removed.

**Chlorides** are found nearly everywhere. They are in water, food, and table salt. One of the worst perpetrator of chlorides can come from household and industrial cleaners.

## **Review**

1. Stainless steels do rust when: Passivity (film-shield) breaks down by scrapes or scratches by deposits and chlorides.
2. Stainless steel rust starts with pits and cracks.
3. Use the proper tools. Do not use steel pads, wire brushes or scraper. (Step 1)
4. Use non-chlorinated cleaners at recommended concentrations. Use only chloride free cleaners. (Step 3)
5. Soften your water. Know the hardness of your water. Use filters and softeners whenever possible. (Step 4)
6. Wipe off cleaning agent(s) and standing water ASAP. Prolonged contact will cause eventual problems. (Step 6)

To learn more about chloride-stress corrosion and how to prevent it, contact the manufacturer of your equipment, your cleaning materials supplier or NAFEM.

NAFEM  
N. American Association of Food  
Equipment Manufacturers  
401 N. Michigan Avenue  
Chicago, Illinois 60611-4267  
(312.644.6610) E-mail: NAFEM@hq\_sba.com

Developed for NAFEM by  
an independent testing laboratory,  
Packer Engineering of Naperville, Illinois



# **Notes**